



United Kingdom of Great Britain and Northern Ireland
**Certificate of EC type-examination of a
measuring instrument**

Number: UK/0126/0013 Revision 1

issued by the Secretary of State for Innovation, Universities & Skills
Notified Body Number 0126

In accordance with the requirements of the Measuring Instruments (Automatic Catchweighers) Regulations 2006 (SI 2006/1257) and the Measuring Instruments (Non-Prescribed Instruments) Regulations 2006 (SI 2006/1270) which implement, in the United Kingdom, Council Directive 2004/22/EC, this certificate of EC type-examination has been issued to:

**Mount Systems Packaging Ltd
Shawcross Business Park
Owl Lane
Dewsbury
West Yorkshire
United Kingdom**

in respect of an automatic checkweighing instrument designated the MAC-20 and having the following characteristics:

Number of scale intervals:	≤ 10000
Minimum capacity (Min):	$\geq 20 e$
Scale interval:	$\geq 1 g$
Accuracy class:	XIII (0.5)

The necessary data (principal characteristics, alterations, securing, functioning etc.) for identification purposes and conditions (when applicable) are set out in the descriptive annex to this certificate.

This revision replaces previous versions of this certificate.

Signatory: P R Dixon
for Chief Executive
National Weights & Measures Laboratory
Department for Innovation, Universities and Skills
Stanton Avenue
Teddington
Middlesex TW11 0JZ
United Kingdom

Issue Date: 27 February 2008
Valid Until: 20 November 2017
Reference No: T1108/0041

Descriptive Annex

1 INTRODUCTION

This pattern of an automatic checkweighing instrument, designated the MAC-20, comprises an indexing load transport mechanism, incorporating a load receptor supported by strain gauge load cells, a PLC and a digital weight indicator.

The MAC-20 is used for automatically weighing containers. The containers are transported onto the load receptor by the indexing system where they are weighed statically. The weight indicator determines when the weight is stable. The weight data is then transmitted to peripheral equipment for processing under the Average Weight System.

2 FUNCTIONAL DESCRIPTION

2.1 Mechanical

The MAC-20 incorporates an indexing load transport mechanism. The indexing system is chain driven and incorporates a series of mechanical guides at regular spaced intervals. The spacing is equivalent to the length of the load receptor to ensure that only one container is on the load receptor at a time. The indexing system transports containers from an infeed onto the load receptor. When the container is on the load receptor the mechanical guide retracts so that the container is supported only by the load receptor. Following the weighing operation the indexing system moves the container onto an outfeed, where it can then be passed onto further handling systems. The load receptor is supported by strain gauge load cells which are connected to a digital weight indicator. A Programmable Logic Controller mounted in a separate enclosure provides overall control of the indexing system and informs the indicator when to start the weighing process.

2.2 Load cells

Any compatible load cells may be used providing the following conditions are met:

- (i) There is a respective OIML Certificate of Conformity (R60) or a test certificate (EN45501) issued for the load cell by a Notified Body responsible for type examination under Directive 90/384/EEC.
- (ii) The certificate contains the load cell types and the necessary load cell data required for the manufacturer's declaration of compatibility of modules (WELMEC 2, Issue 3, 2000, No 11), and any particular installation requirements. A load cell marked NH is allowed only if humidity testing to EN45501 has been conducted on this load cell.
- (iii) The compatibility of the load cells and indicator is established by the manufacturer by means of the compatibility of modules calculation, contained in the above WELMEC 2 document, at the time of verification or declaration of EC conformity of type.
- (iv) The load cell transmission must conform to one of the examples shown in the WELMEC Guide 2.4, "Guide for Load cells".

2.3 Electrical

The MAC-20 comprises one of the following digital weight indicators:

- Ian Fellows CSW-20
- Ian Fellows 2X
- Bizerba ST-Ex

2.4 Devices

The indicators have the following devices:

- self-test sequence and display check during power-up
- determination of the stability of equilibrium
- calibration/set-up access via keyboard with traceable access number [TAN] (CSW-20)
- calibration/set-up access via a button on the main board (2X)
- calibration/set-up access via bridge link on the main board (ST – Ex)
- initial zero-setting, overall effect $\leq 20 \%$
- semi-automatic zero-setting
- zero-tracking
- indication of stable equilibrium
- semi-automatic subtractive tare (not operable during automatic operation)

3 TECHNICAL DATA

3.1 The MAC-20 has the following characteristics:

Number of scale intervals:	≤ 10000
Minimum load (Min):	$\geq 20 \text{ e}$
Scale interval:	$\geq 1 \text{ g}$
Maximum throughput:	$\leq 35 \text{ packs/min}$
Tare:	$\leq - \text{Max}$
Accuracy class:	XIII (0.5)
Power supply	110/240 VDC, 50/60Hz

3.2 The indicators have the following characteristics:

Indicator	CSW-20	2X	ST-Ex
Power supply	110/120 VAC - 50/60 Hz 220/240 VAC - 50/60 Hz	110/120 VAC - 50/60 Hz 220/240 VAC - 50/60 Hz	100/240 VAC - 50/60 Hz 20/30 VDC 10/30 VDC battery
Minimum input signal per scale interval	1 $\mu\text{V/div}$	1 $\mu\text{V/div}$	0.4 $\mu\text{V/div}$
Load cell excitation	5 V DC	10 V DC	5 V DC
Minimum input impedance	43 Ω	43 Ω	87 Ω
Fractional error p_i	0.5	0.5	0.5
Max cable length (m/mm2)*	150	10,000 / n * 385	380

* : indicator to junction of cell cable(s)

3.3 Documentation and drawings

MAC-20 Checkweigher	ML0747
MAC-20 Block Diagram	ML0659/2
Ian Fellows CSW-20	30-M-1163
Ian Fellows 2X	26-M-79526-M-795
Bizerba ST-EX	ML0752

3.4 Software

3.4.1 PLC

3.4.1.1 The software in the PLC is designated CW459459, and is password protected. Only the manufacturer has the password.

3.4.1.2 The PLC may transmit via the serial port the following data to the indicator (2X only): tare, target weight and high and low tolerance, as well as dribble weight and in-flight weight from the filling instrument providing the packs to be weighed. The software is then designated CW459460.

3.4.2 CSW-20 indicator

The indicator software has the version number PO6_xxx, which is displayed at power-up along with the traceable access number [TAN]. Any calibration is password protected, and can therefore be performed only by authorised personnel, and generates a traceable access number [TAN] that must be written on the rating plate after every modification.

3.4.3 2X indicator

3.4.3.1 The indicator software has the version number F2MP00903, which is displayed at power-up. Any calibration needs access to the calibration switch located on the main board, protected by seals on the enclosure, and can therefore be performed only by authorised personnel.

3.4.3.2 The indicator may transmit via the serial port the following data to the weighing indicator of the filling instrument providing the packs to be weighed: target weight, dribble weight and in-flight weight. The software is then designated F2MP009XX.

3.4.4 ST-Ex indicator

The indicator software has the version number 6.457.51.004.53SP1, which is displayed at power-up. Any calibration needs access to the calibration bridge link located on the main board, protected by seals on the enclosure, and can therefore be performed only by authorised personnel.

3.4.5 Software download

Any software download requires breaking the seals on the indicators, and needs changing of the EPROM. This operation must be carried out only by authorised personnel and the action must be recorded as well as the new version number when the seals are replaced.

4 PERIPHERAL DEVICES AND INTERFACES

4.1 Interfaces

The indicators have the following interfaces:

- Communication port (RS232, RS485)
- Printer port, serial port (RS232)
- Control I/O

4.2 Peripheral devices

4.2.1 The checkweigher may be connected to:

- a Mount Packaging Systems Ltd “Trendsetter II” terminal
- a CE-marked PC running approved Average Weight (“e-mark”) Software

4.2.2 The checkweigher may also be connected to:

- (i) any peripheral device that has been issued with an evaluation (test) certificate by a Notified Body responsible for Annex B (MI-006) under Directive 2004/22/EC in any Member State and bears the CE marking of conformity to the relevant directives; or
- (ii) peripheral devices without an evaluation (test) certificate, under the following conditions:
 - it bears the CE marking for conformity to the EMC Directive 89/336/EEC;
 - it is not capable of transmitting any data or instruction into the weighing instrument, other than to release a printout, checking for correct data transmission or validation;
 - it prints weighing results and other data as received from the weighing instrument without any modification or further processing;
 - it complies with the applicable requirements of EN45501, i.e. 4.2, 4.4, 4.6 and 4.7.

5 APPROVAL CONDITIONS

The certificate is issued subject to the following conditions:

5.1 Legends and inscriptions

5.1.1 The instrument bears the following legends:

‘CE’ marking
Supplementary metrology marking
Notified body identification number
Accuracy class
Serial number
Manufacturers mark or name
Certificate number
Min
Max
e =

6 LOCATION OF SEALS AND VERIFICATION MARKS

6.1 The 'CE' marking, supplementary metrology marking and certificate number are located on the side of the control console. The CE mark shall be impossible to remove without damaging it. The data plate shall be impossible to remove without it being destroyed.

The markings and inscriptions shall fulfil the requirements of Paragraph 9 of Annex I of the Directive 2004/22/EC.

6.2 Calibration/set-up data is stored within a non-volatile memory on the indicators, and can only be accessed from the keypad with a password (CSW-20), or by pressing a button on the main board (2X) or by removing a link on the main board (ST-Ex), both protected by seals. Whenever this data is modified, a traceable access number [TAN] is incremented and must be written on the rating plate (CSW-20), or the seal must be broken (2X and ST-Ex), with this operation being recorded as well as the calibration/set-up data when the seal is replaced.

6.3 Components that may not be dismantled or adjusted by the user will be secured by either a wire and seal or tamper evident label and securing mark. The securing mark may be either:

- a mark of the manufacturer and/or manufacturer's representative, or
- an official mark of a verification officer.

7 ALTERNATIVES

There are at present no alternatives.

8 ILLUSTRATIONS

- Figure 1 MAC-20 checkweigher
Figure 1 Photograph of the MAC-20
Figure 3 MAC-20 block diagram (with CSW-20 indicator)
Figure 4 CSW-20 digital weight indicator
Figure 5 2X digital weight indicator
Figure 6 ST-Ex digital weight indicator

9 CERTIFICATE HISTORY

ISSUE NO.	DATE	DESCRIPTION
UK/0126/0013	21 November 2007	Type examination certificate first issued.
UK/0126/0013 Rev 1	27 February 2008	Sections 3.4.1.2 and 3.4.3.2 added.

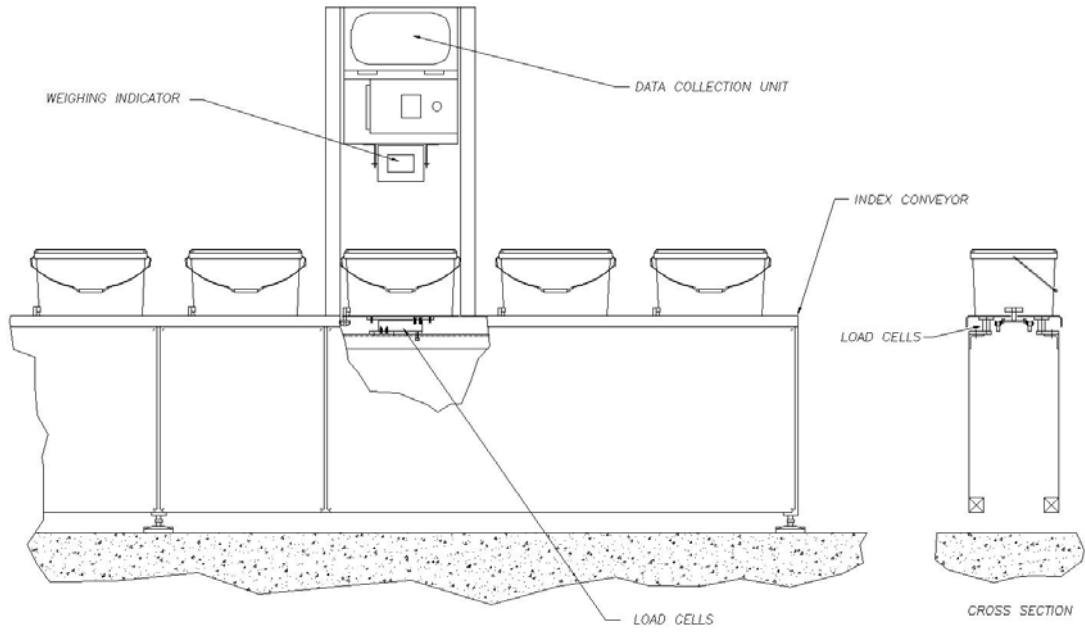

Figure 1 MAC-20 checkweigher



Figure 2 Photograph of the MAC-20

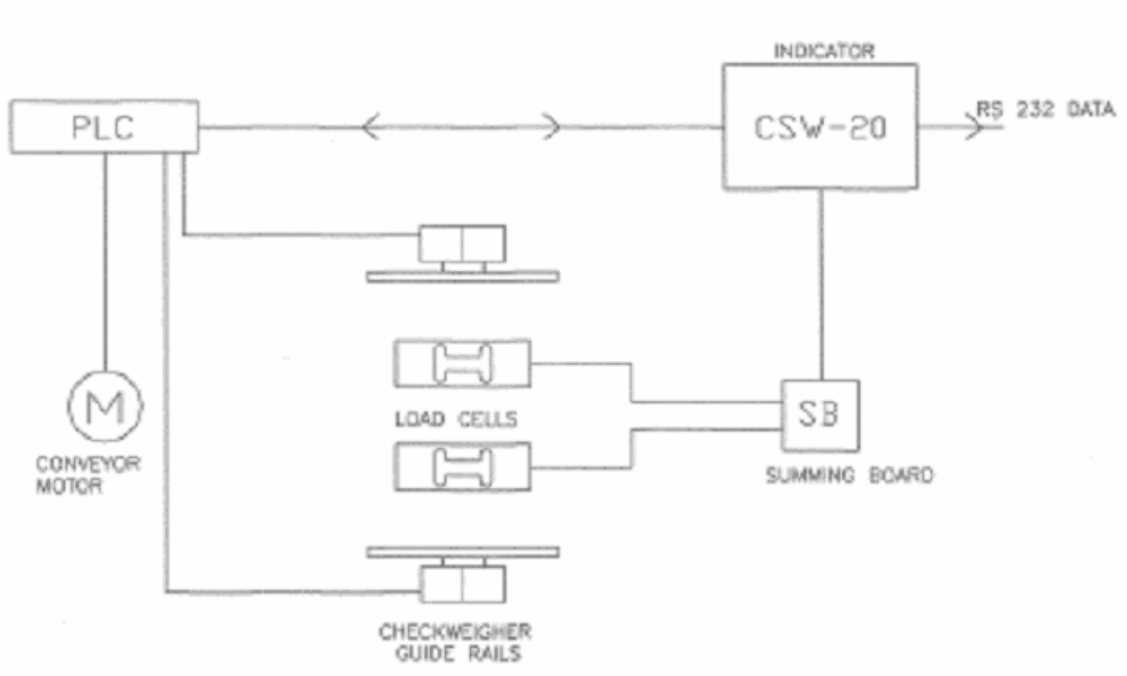

Figure 3 MAC-20 block diagram (with CSW-20 indicator)



Figure 4 CSW-20 digital weight indicator



Figure 5 2X digital weight indicator



Figure 6 ST-Ex digital weight indicator