



United Kingdom of Great Britain and Northern Ireland

Certificate of EC type-examination of a measuring instrument

Number: UK/0126/0017

issued by the Secretary of State for Trade and Industry
Notified Body Number 0126

In accordance with the requirements of the Measuring Instruments (Liquid Fuel delivered from Road Tankers) Regulations 2006 (SI 2006/1259) and the Measuring Instruments (Non-Prescribed Instruments) Regulations 2006 (SI 2006/1270) which implement, in the United Kingdom, Council Directive 2004/22/EC, this certificate of EC type-examination has been issued to:

Mechtronic Ltd
15 Lower Wortley Road
Wortley
Leeds
LS12 4RY
United Kingdom

in respect of a vehicle-mounted liquid fuel meter measuring system designated the Max flow and having the following characteristics:

<i>Model designation</i>	<i>Mechtronic 'Maxflow 400' or 'Maxflow 800'</i>
<i>Maximum rate of flow</i>	<i>400 litres / minute (hosereel)</i> <i>800 litres / minute (bulk hose)</i>
<i>Minimum rate of flow</i>	<i>150 litres / minute</i>
<i>Maximum operating pressure</i>	<i>8 bar</i>
<i>Minimum delivery</i>	<i>500 litres: pumped hosereel</i>
<i>Liquids measured</i>	<i>Derv; Gas oil; Kerosene, Paraffin</i>

The necessary data (principal characteristics, alterations, securing, functioning etc) for identification purposes and conditions (when applicable) are set out in the descriptive annex to this certificate.

Signatory: P R Dixon
for Chief Executive
National Weights & Measures Laboratory
Department of Trade and Industry
Stanton Avenue
Teddington
Middlesex TW11 0JZ
United Kingdom

Issue Date: 18 July 2007
Valid Until: 17 July 2017
Reference No: T1121/0007

Descriptive Annex

1 INTRODUCTION

This pattern is a meter measuring system inclusive of a product return system fitted to a road tanker for the transport and delivery of liquids with low viscosity stored at atmospheric pressure.

It comprises a multi-compartment tank, an optional multi-compartment manifold pipe and valve system, an optional pump fitted with a pneumatic relief valve, filters, a meter, a special gas extractor, a full hose reel, a bulk delivery line, selector valve and compatible ancillary equipment. A product return system is fitted complete with non return valves, guard bar assembly and interlock system. The system allows:

- (a) metered delivery by pumping (full hose)
- (b) metered delivery by pumping (empty hose)
- (c) direct delivery, with or without pumping, without passing through the meter.
- (d) unlimited product return, including transfer of product from one compartment to another.
- (e) self loading without passing through the meter.

The hydraulic system is shown in Figures 1 and 2 which is followed by a key (Figure 4).

2 CONSTRUCTION

2.1 Mechanical

2.1.1 Hydraulics

The hydraulic system is shown in Figures 1 and 2. Liquid may flow from any of the selected compartments of the cargo tank via the appropriate foot valve and manifold valve into the manifold. From there it passes through an electronically controlled special gas extractor **SgP** which is fitted within the manifold which in turn acts as the outlet from the manifold into the pump suction pipe. The liquid then passes through an optional flexible coupling or hose into a cargo pump fitted with a pneumatically operated relief valve **P, PRv**. From there it passes through an optional 2 way valve **R2** which allows a metered delivery or un-metered bulk delivery. Metered deliveries pass through an optional filter, meter **C**, flow sensing valve **FSv**, system isolation valve **PIV**, 2 way valve which allows full hose or empty hose delivery **R3**, hosereel **FH1**, hose and trigger nozzle **cla**.

2.1.2 Special gas extractor

A schematic is shown in Figure 3. This is a form of 'special gas extractor' manufactured by Mechtronic Ltd type MF400. The MF400 consists of a housing optionally secured between two manifold valves thus forming part of the manifold pipe. The housing is closed off by a housing lid. The MF400 contains an optic detector probe, **S1**, a microprocessor controlled vent valve, **T3**, and a fitting used to connect an optional manifold balance pipe. The housing also provides for a second optic probe, **S2**, fitted into the lower part of the housing just prior to the outlet flange.

Both top and bottom probes, **S1** and **S2**, are connected to the special gas extractor electronic control unit, **CU**. The special gas extractor electronic control unit converts the signals received from the optic probes into pneumatic/electrical signals controlling the pneumatic relief valve, **PRv**, on the pump, the system isolation valve, **PIV**, and the gas extractor vent valve, **T3**.

Gas from the MF400 is vented, via a valve, controlled by the special gas extractor electronic controller, into a liquid collection tank, **T1**. The collection tank is vented to atmosphere and is fitted with a drain valve, **Dv**.

2.1.3 Meter

This is a Tuthill Transfer Systems FPP Meter Division positive displacement meter, approved by EEC certification No UK04 2702. The pattern is a rotary positive displacement type meter with two oval gear rotors. Optionally, any suitable approved meter type may be used.

2.1.4 Meter head assembly

The meter head assembly comprises of the following Veeder-Root equipment

- | | | |
|-----|-------------------------|---------------|
| (a) | Counter | VR 7887XX-XXX |
| (b) | Ticket printer | VR 7888XX-XXX |
| (c) | Preset | VR 788901-XXX |
| (d) | Counter/printer | VR 7890XX-XXX |
| (e) | Register/Preset/Printer | VR78920X-XXX |

2.1.5 Pump

This pattern will accept any Pump fitted with a pneumatically operated relief valve capable of producing the required minimum and maximum flow rates and pressures.

2.2 Electronics

2.2.1 Veeder-Root EMR³ Electronic register (Figure 10)

The Veeder-Root EMR³ electronic register head is mounted in the control cabinet and it receives pulses from an encoder mounted directly on the meter. These pulses are processed and connected via cable to the EMR³ interconnect box (usually in the cab) which contains control and calculation functions and which interfaces with the printer.

2.2.1.1 Where interface with pneumatic control systems is required, an interface unit may be provided. A typical unit is shown in Figure 13.

2.2.1.2 Interlock functions are maintained and a ticket must be printed before the next transaction can start.

2.2.1.3 Software

The software issue status of the EMR³ is displayed upon switch-on. The software version numbers are:

- | | | |
|-----|------------------|----------------|
| (a) | Register head | 349785-001-XXX |
| (b) | Interconnect box | 349784-001-XXX |

The legally relevant software, as represented by the middle section (001) in the above version numbers, may not be changed without the prior approval of the National Weights and Measures Laboratory. XXX represents the version number pertaining to the manufacturer's part of the software and may be freely altered.

2.2.1.3.1 Software security

Recalibration and the amendment of calibration constants, labels, etc, may only be done when the EMR³ Register head is in the calibration control (C&C) mode. The C&C mode is accessible on the front panel of the display unit. To prevent unauthorised adjustment, a metal knurled threaded cover is screwed over the adjustment control. This cover is secured in position by passing a sealing wire through a pre-drilled hole in the cover and running it via pre-drilled holes in the heads of two adjacent panel securing screws. The wire ends are drawn taught and sealed with an approved seal.

2.2.1.3.2 Calibration factor

Calibration is effected in the C&C mode and may be performed manually or automatically. Additionally, calibration may be carried out at each of 8 different flow rates. The number entered scales the pulses for the volume metered. After calibration, this number cannot be altered without breaking the seal on the Register Head.

2.2.2 Special gas extractor

The special gas extractor electronic control unit houses both the electronic control module and solenoid operated pneumatic valves in the one housing. The front cover of the housing allows viewing of the status LEDs. The LEDs give the operator a real time status of the special gas extractor's optic probes and the open closed status of the special gas extractor vent valve, the pump relief valve and the system stop start valve. The software version number (1.1) is displayed through the front panel. Access to the software is limited either by the manufacturers security device or (on later manufacture) by 'potting' the device and by the omission of any programming interface port thus precluding any change to the software.

2.2.2.1 Power supply

The special gas extractor electronic control is powered by the vehicle battery. In the event of a power failure all pneumatic valves fail in the normally closed state thus stopping the delivery. The delivery can not be restarted until power is reinstated. The special gas extractor electronic control unit is optionally switched on and off by a pressure switch connected to the power take off pneumatic engagement signal.

2.3 Product return

The system is designed to allow product to be returned to a compartment to permit the changeover of product following the completion of a delivery, but to inhibit product return until the ticket from that delivery has been withdrawn.

2.3.1 Hydraulics

The system is shown in Figures 1 and 2, which is accompanied by a key in Figure 4. A general view is shown in Figure 6.

3 PERIPHERAL DEVICES AND INTERFACES

3.1 Interfaces

The instrument may have the following interfaces:

- (a) Interconnection box (RS 485)
- (b) Quadrature pulse input (5V TTL logic)

The Interconnection Box has the following interfaces:

- (a) Register head (RS 485) up to two possible from one IB (both with intrinsically safe supply)
- (b) Printer (RS 232)
- (c) 12 or 24 volt power supply

3.2 Peripheral devices

The printer is typically an Epson TM-U295 slip printer. It is used for printing delivery tickets showing the date and time of a delivery, the ticket number, the quantity delivered, the price and other operator entered details. The nature and format of the ticket record is set up using the Register menu system.

Any simple recipient printer may be used in place of the Epson TM-U295 printer provided:

- (i) it bears the CE mark for conformity to the EMC Directive 89/336/EEC;
- (ii) it is not capable of transmitting any data or instructions into the EMR³ other than for releasing the printout, checking for correct data transmission;
- (iii) it prints delivery results and other data as received from the EMR³ without any modification or further processing.

4 TECHNICAL DATA

Technical data	80 mm system	unit
Nominal bore:	50 and 80	mm
Maximum rate of flow:	800	litres / minute
Minimum rate of flow:	150	litres / minute
Maximum working pressure:	8	bar
Minimum delivery Hose:	500	litres
Minimum delivery Bulk:	1000	litres
Liquids measured:	Paraffin; kerosene; derv; gas oil	
Climatic environment:	-10 °C to +40 °C	
	Open, condensing	
Electromagnetic environment:	E3	
Mechanical environment:	M2 (vehicle mounted)	
Accuracy class:	0.5	

Note: The maximum rate of flow, however, must not be greater than the maximum rate of flow of any component of the system.

5 OPERATION

5.1 Description

The system allows pumped metered deliveries through the full hose reel and empty bulk discharge hose, pumped un-metered deliveries and optional un-metered self loading.

Metered deliveries. The direction of flow is controlled by a pneumatically operated 2 way valve **R3**, directing flow to either the full hose or empty hose delivery system. Interlocks are provided to ensure that the 2 way valve **R3** if operated during a delivery will cease the delivery. After completion of an empty hose delivery the hose is cleared of product by introducing compressed air into the system from air tank **AT** via blow down valve **Bd**. Sight glass **Sg**, provides indication of an empty hose.

Un-metered deliveries. The direction of flow is controlled via a manual 2 way valve **R2** situated between the pump and meter. Movement of this valve during a metered delivery will have no effect upon the integrity of the metered delivery. Once liquid has passes the meter there are no other possible outlets other than the hose end nozzle or the empty bulk hose.

Optional self loading of the vehicle is permitted as the auxiliary suction is taken from the manifold which is situated upstream of the special gas extractor. When in self loading mode the special gas extractor is shut down thus closing the product isolation valve. No metered deliveries can be made whilst the external suction valve is open.

The pneumatic and electronic circuitry has been designed on a fail safe principle, such that in the event of pneumatic failure, disconnection or electrical failure then the system will shut down.

5.1.1 Veeder-Root mechanical head assembly

Metered delivery is set up by selecting the product and thus the compartment to be opened. The power take off is engaged energising the manifold control system and special gas extractor control unit. The manifold valve is then opened. The 2 way valve **R2** is set for metered delivery and then the 2 way valve **R3** is set for either full hose or empty hose delivery. If a preset delivery is required then the meter preset is set. A ticket is inserted into the meter and the meter preset valve is opened. Once the hose end nozzle is opened the delivery will commence. The special gas extractor will control the rate of flow via the pump relief valve and the product isolation valve during the delivery ensuring that no air/gas can leave the special gas extractor during the delivery. At the completion of the delivery the ticket is printed and the system shut down.

5.1.2 Veeder-Root EMR³ electronic register

Metered delivery is set up by selecting the product and thus the compartment to be opened. . A ticket is inserted into the ticket printer. The power take off is engaged energising the manifold control system and special gas extractor control unit. The manifold valve is then opened. The 2 way valve **R2** is set for metered delivery and then the 2 way valve **R3** is set for either full hose or empty hose delivery. If a preset delivery is required then the EMR³ electronic register preset is set and the meter preset valve is opened. Once the hose end nozzle is opened the delivery will commence. The special gas extractor will control the rate of flow via the pump relief valve and the product isolation valve during the delivery ensuring that no air/gas can leave the special gas extractor during the delivery. At the completion of the delivery the ticket is printed and the system shut down.

Each ticket is sequentially numbered, indicates the quantity of liquid fuel delivered in each transaction and is issued at the point of delivery.

5.2 System incorporating product return

5.2.1 Operation - mechanical meter head

5.2.1.1 Normal delivery

At the start of a delivery when the ticket is inserted and the printer handle is operated, the ticket is positioned by a slider and locked in place by a retaining pin that passes through a punched hole in the ticket. Closing the slide blocks the pneumatic signal to the product isolation valve **PIV** (Figure 1) rendering it closed. With the product return guard bar in its closed position a cam within the product return arm operates pneumatic valve **GbV** (Figure 1) sending a pneumatic signal to the product isolation valve thus opening the valve. Delivery is carried out normally. On completion, the printer handle is operated to print and releases the ticket.

5.2.1.2 Product return

For product changeover, the mechanical catch holding the product return bar in its closed position is released and the product return guard bar raised, the wet-hose nozzle is then connected to the product transfer spout, which incorporates a non-return valve. Once raised, the pneumatic valve **GbV** actuated by the product return arm cam shuts off the pneumatic signal to the product isolation valve **PIV** rendering the valve closed. If a ticket is still in the printer then the printer handle is operated to print and release the ticket from the previous delivery. This opens **PrV** and sends a pneumatic signal to the product isolation valve **PIV** thus opening the valve. The quantity of product to be returned is entered on the pre-set device and pumping is started.

When the product return is complete, the meter pre-set shuts off product flow and the hose-end nozzle is manually closed. The blowdown valve **Bd** is manually opened. This allows compressed air from the air tank **AT** to purge product from the bottom-loading pipework from **Pt** back into the compartment. Duration is approximately 2-5 seconds. The hose end nozzle is then removed from the product return spout, the product return guard bar lowered into its rest position which then deactivates the product return system.

5.2.2 Security features and interlocks

5.2.2.1 If, during a normal delivery, the product return guard bar is raised, the presence of a ticket in the printer releases the pneumatic signal to the product isolation valve **PIV** and stops the flow of product.

5.2.2.2 If a ticket is inserted into the printer during the product return operation, the pneumatic signal from **PrV** to the product isolation valve **PIV** will be lost. This will close the product isolation valve **PrV** and product transfer will cease.

5.2.2.3 Product cannot be diverted into a compartment via a product transfer connector during a normal delivery because the raising of the product return guard bar causes the product isolation valve **PrV** to close and flow will cease.

5.2.3 Operation - electronic meter head - EMR³

5.2.3.1 For product changeover, the mechanical catch holding the product return bar in its closed position is released and the product return guard bar raised, the wet-hose nozzle is then connected to the product transfer spout, which incorporates a non-return valve. Once raised, the pneumatic valve **GbV** actuated by the product return arm cam sends a signal to a pressure switch which identifies to the system that product transfer is in use. The quantity of product to be returned is entered on the pre-set device and pumping is started.

When the product return is complete, the meter pre-set shuts off product flow and the hose-end nozzle is manually closed. The blowdown valve **Bd** is manually opened. This allows compressed air from the air tank **AT** to purge product from the bottom-loading pipework from **Pt** back into the compartment. Duration is approximately 2-5 seconds. The hose end nozzle is then removed from the product return spout, the product return guard bar lowered into its rest position which then deactivates the product return system. The system will then print the words “product transfer” on the delivery ticket.

The software issue status of the EMR is displayed upon switch-on. Current issue status is C05 (without product return) or C06 (product return version).

5.2.3.2 Security features and interlocks

If during a normal delivery, the product return guard bar is raised, the delivery is terminated and a ticket is automatically produced detailing the volume of product delivered.

6 APPROVAL CONDITIONS

The certificate is issued subject to the following conditions:

6.1 Legends and inscriptions

6.1.1 The instrument bears the following legends:

- ‘CE’ marking
- Supplementary metrology marking
- Notified body identification number
- Accuracy class
- Serial number
- Manufacturers mark or name
- Certificate number
- The liquids measured: Derv; Gas oil, Kerosene, Paraffin

6.1.2 Systems with EMR³ registers having the Tank serial numbers listed below shall have the Set-Up security code enabled which locks out both the setup mode and C&C. The code will only be available to Mechtronic Ltd engineers.

Serial numbers: 021537
 031538
 97255

6.2 The vehicle must be provided with a stable and adequate ground/earth system during delivery.

7 LOCATION OF SEALS AND VERIFICATION MARKS

7.1 Location of markings and securing (sealing) arrangements

The following shall be sealed to prevent unauthorised adjustment or dismantling:

- (a) The EMR³ electronic register shall be sealed as shown in Figure 10. The register shall be sealed as described in section 2.2.2.3.
- (b) The EMR³ Interconnect box shall be sealed under the cover as shown in Figure 12.
- (c) The plate referred to in Section 5 shall be sealed or welded to a support of the system.
- (d) Any flexible pipe work fitted between the special gas extractor and pump shall be sealed using wire and lead seals.

8 AUTHORISED ALTERNATIVES

Having the following authorised alternatives

8.1 Having the system as described in the descriptive annex but without the Mechtronic product return system.

8.2 Having the special gas extractor electronic control cabinet manufactured so that the electronic control module is separate from the pneumatic control thus allowing maintenance work to be carried out on the pneumatic components without breaking the electronic module's seal.

9 RECOMMENDED TESTS

9.1 The meter measuring system shall be tested at a minimum of two substantially different rates of flow between the maximum and minimum rates of flow.

9.2 The meter measuring system shall be tested by a minimum of three repeat runs at each rate of flow. Each run shall have a minimum duration of one minute.

9.3 Due regard shall be paid to the viscosity of the liquid used for the verification tests to ensure that the permitted limits of error are not likely to be exceeded when other liquids which the system is intended to measure are metered.

9.4 If the optional self loading connection is present, then whilst in normal metered delivery mode activate the valve R1. The system must shut down.

9.5 Verify that the interlocks operate as described.

9.6 Verify the software issue status.

9.7 Verify that the E04 threshold value in the EMR³ register is set to no greater than 50.

10 ILLUSTRATIONS

- Figure 1 Hydraulic diagram - mechanical meter head
Figure 2 Hydraulic diagram - electronic meter head - EMR3
Figure 3 Schematic diagram of special gas extractor components
Read in conjunction with Figures 1 and 2
Figure 4 Key to hydraulic diagrams Figures 1, 2 and 3
Figure 5 Typical view of special gas extractor
Figure 6 Manifold and product return assembly
Figure 7 Typical view of special gas extractor control unit (electronic)
Figure 8 Typical view of special gas extractor control unit (mechanical)
Figure 9 Typical view of special gas extractor LED display and logic
Figure 10 Remote display front panel showing method of sealing
Figure 11 EMR³ Interconnect Box (IB)
Figure 12 EMR3 interface box sealing
Figure 13 Pneumatic interface box

11 CERTIFICATE HISTORY

ISSUE NO.	DATE	DESCRIPTION
UK/0126/0017	18 July 2007	Type examination certificate first issued.

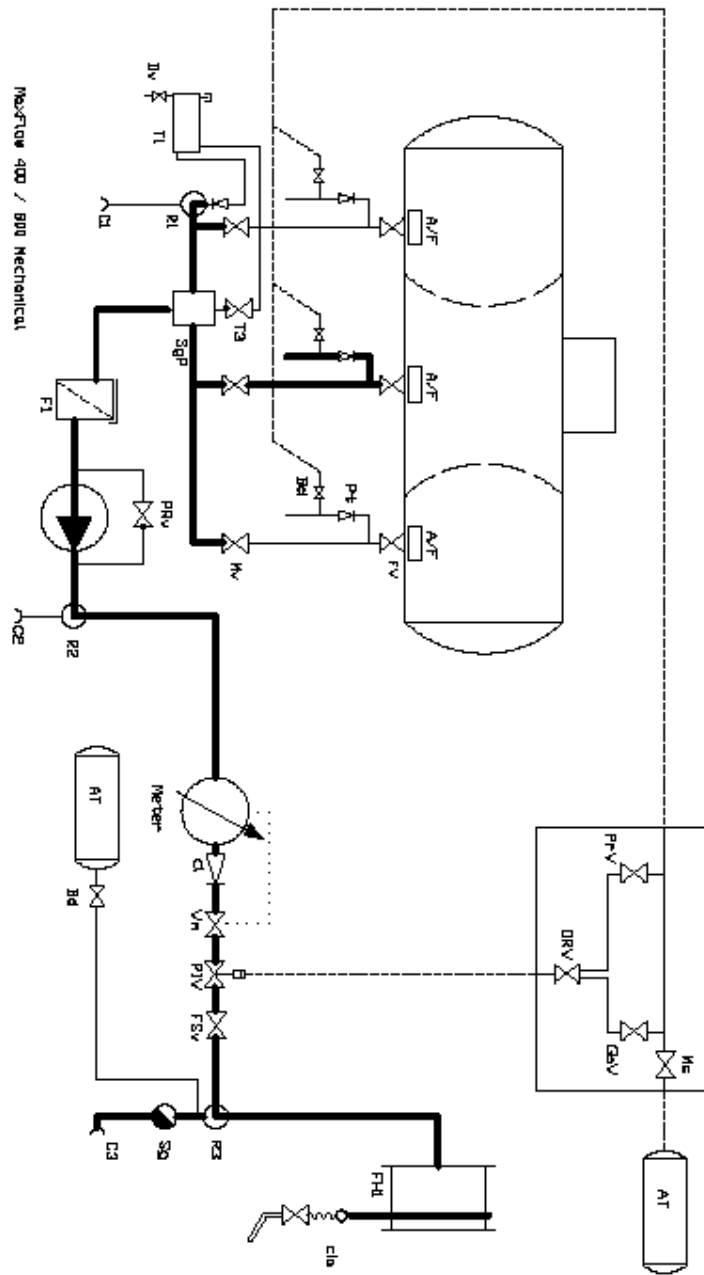
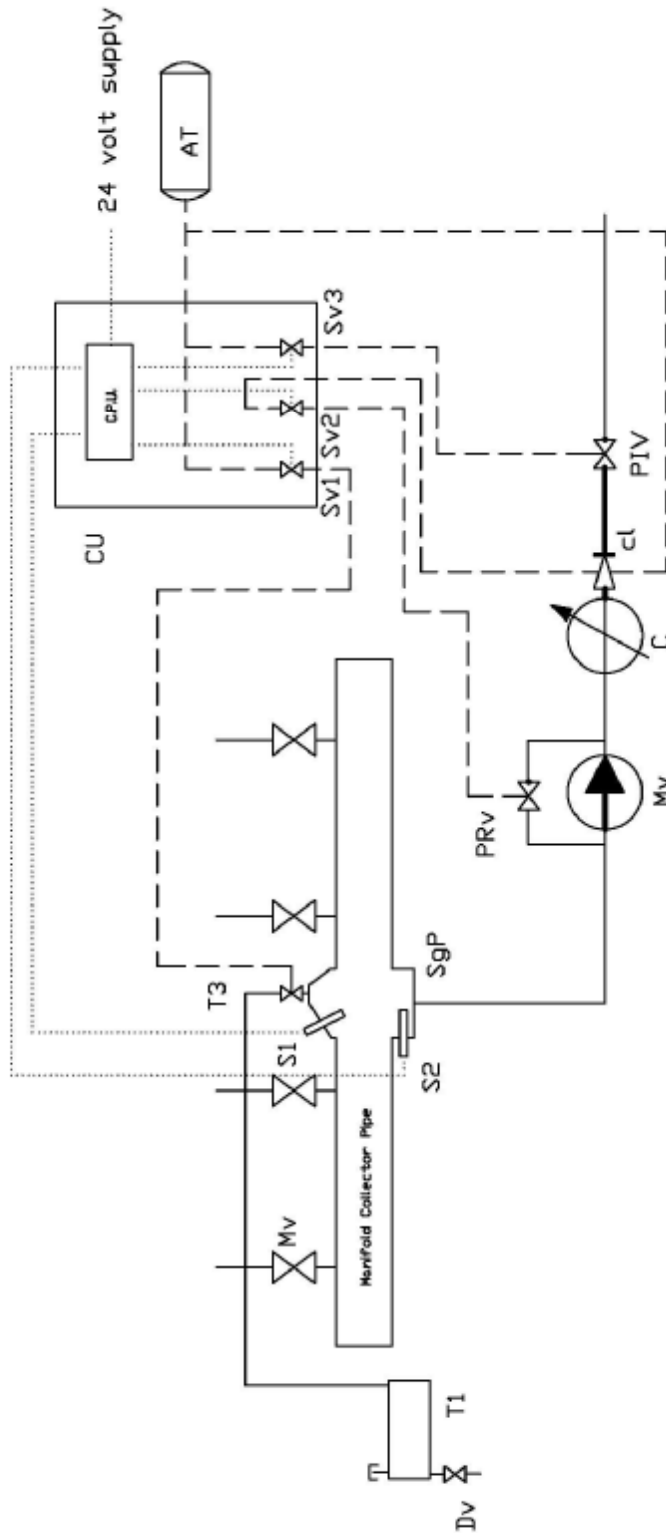

Figure 1 Hydraulic diagram - mechanical meter head



**Figure 3 Schematic diagram of special gas extractor components
(Read in conjunction with Figures 1 and 2)**

A/F	Anti-swirl device
Mv	Manifold valve. Transfer of liquid between compartments is prevented by the use of double acting cylinders ensuring all valves are power closed with the exception of the open valve and control cabinet interlock mechanisms
FV	Compartment foot valve
P	Pump fitted with pneumatically operated relief valve
PRv	Pneumatically operated pump relief valve
R1	Optional valve for auxiliary suction. Interlocks are provided to ensure that PIV remains closed and a metered delivery can not take place
R2	Optional valve for pumped unmetred delivery. Where this is fitted for trade use, the compartments have dipstick measuring systems which are subject to national regulations
R3	2 way valve for selection of full hose or empty hose delivery
F1	Optional suction line filter
F2	Pressure side filter
SgP	Special gas extractor fitted into manifold forming part of manifold pipe.
Vv	Valve fitted to special gas extractor for release of air/gas controlled by the special gas extractor control unit
T ₁	Liquid collection tank which incorporates a vent valve and a drain valve (Dv)
C	Meter.
V _m	Operating valve which may be connected to the pre-setting mechanism of the meter
PIV	Product isolation valve. Controlled by product return system, Interlocks on R1 and Special gas extractor control unit.
FSv	Flow sensing valve.
FH1	Full hose and hose reel
Sg	Sight Glass
cl	Optional non return valve. Can be replaced with flow sensing valve
cla	Trigger nozzle and spout incorporating a valve to prevent the hose from emptying
At	Auxiliary air tank.
Bd	Blow down valve
Ms	Master control switch
PrV	Printer tray valve
GbV	Guard bar valve
ORV	'OR' gate logic valve
PIV	Product isolation valve
Pt	Product transfer spout non return valve.
C1	External suction connection. Interlocked with PIV to remain closed when C1 open
C2	Non metered pumped discharge connection
C3	Empty hose discharge connection
PS	Pressure switch
CU	Special Gas Extractor Control Unit
S1	Top optic detector probe
S2	Bottom optic detector probe
Sv1	Solenoid operated pneumatic valve controlling gas extractor vent valve T3
SV2	Solenoid operated pneumatic valve controlling pump pneumatic relief valve PRv
SV3	Solenoid operated pneumatic valve controlling product isolation valve PIV
T3	Special gas extractor vent valve

Figure 4 Key to hydraulic diagrams Figures 1, 2 and 3

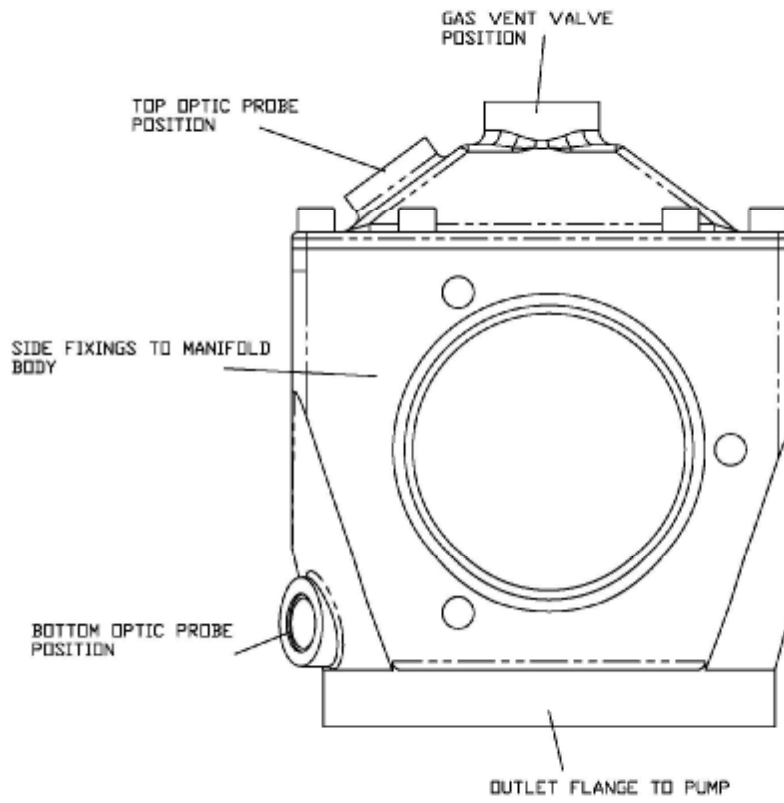

Figure 5 Typical view of special gas extractor

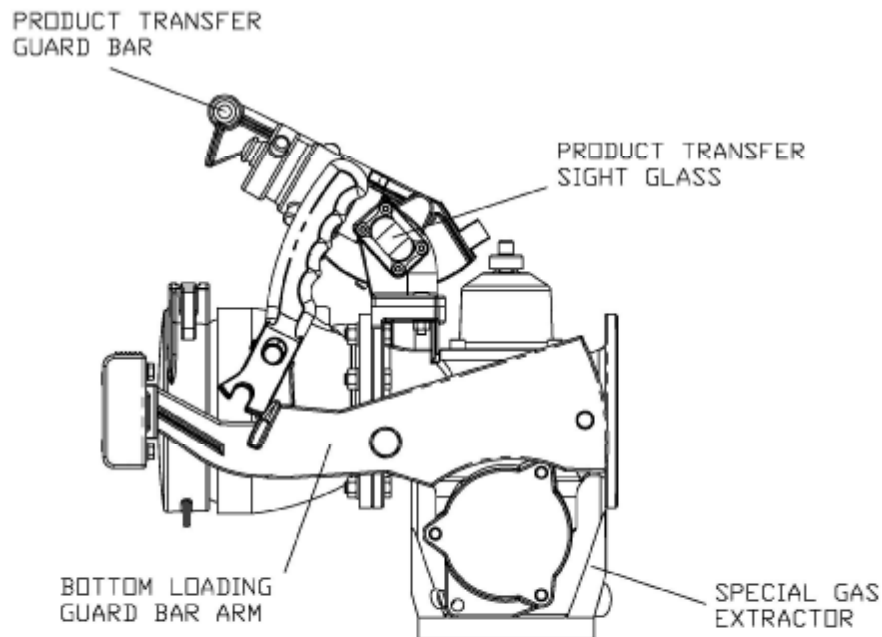
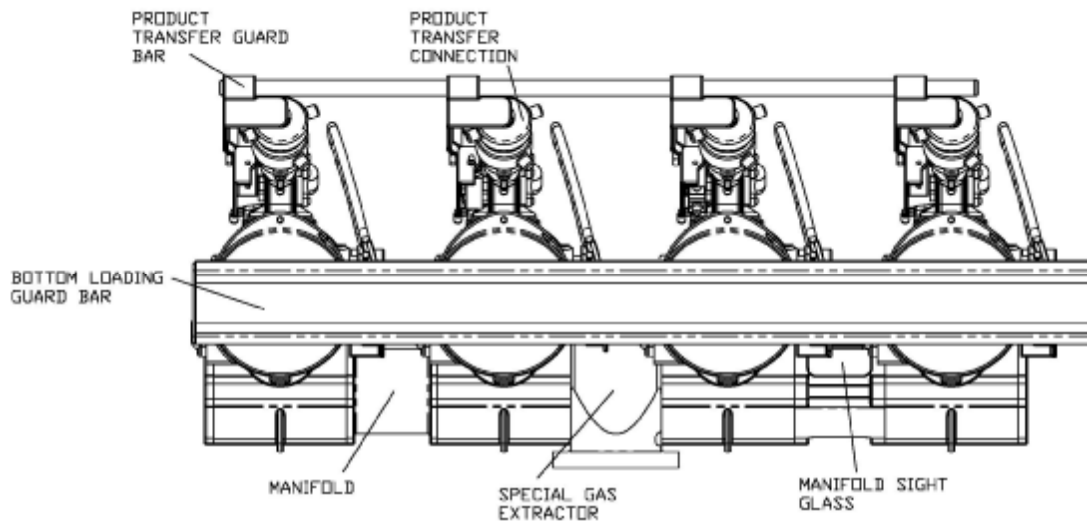

Figure 6 Manifold and product return assembly



Figure 7 Typical view of special gas extractor control unit (electronic)



Figure 8 Typical view of special gas extractor control unit (mechanical)

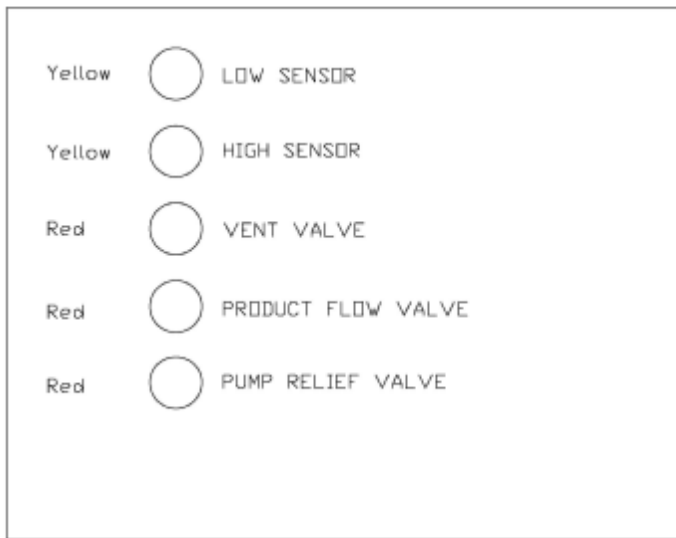

Special gas extractor LED display logic:

- | | | |
|-----|---------------------------------|--|
| (1) | Low sensor flashing | Low sensor dry. |
| (2) | High sensor flashing | High sensor dry. |
| (3) | Vent valve unlit | Vent valve is open. |
| (4) | Vent valve lit | Vent valve closed. |
| (5) | Pump relief valve unlit | Pump relief valve on stand by pressure. Low flow. |
| (6) | Pump relief valve lit | Pump relief valve on full pressure. High flow. |
| (7) | Product flow valve unlit | PIV closed. |
| (8) | Product flow valve lit | PIV open. |
-
- | | | |
|-----|---|---|
| (1) | Both yellow LEDs flashing. | <i>Manifold in dry state. Vent valve open (no flow).</i> |
| (2) | Low sensor lit. High sensor flashing. | <i>Manifold filling. Vent valve open (no flow).</i> |
| (3) | Both yellow LEDs lit. | <i>Manifold full. Vent valve open (no flow).</i> |
| (4) | Both yellow LEDs lit. Vent valve lit. | <i>Manifold full. Vent valve shut (no flow).</i> |
| | System now waits for 10 seconds before next stage. | |
| (5) | Both yellow LEDs lit. Vent valve lit and product flow valve lit. | <i>Manifold full. Vent valve shut, product isolation valve open (slow flow)</i> |
| | System now waits for 5 seconds before next stage. | |
| (6) | All LEDs lit. | <i>Manifold full. Vent valve shut, product isolation open, pump relief valve energised (full flow).</i> |
| (7) | Low sensor lit. High sensor flashing. Flow valve lit. | <i>Vent valve unlit. Pump relief valve unlit. Product gas in manifold. Vent valve open, pump relief valve de-energised (slow flow).</i> |

Figure 9 Typical view of special gas extractor LED display and logic

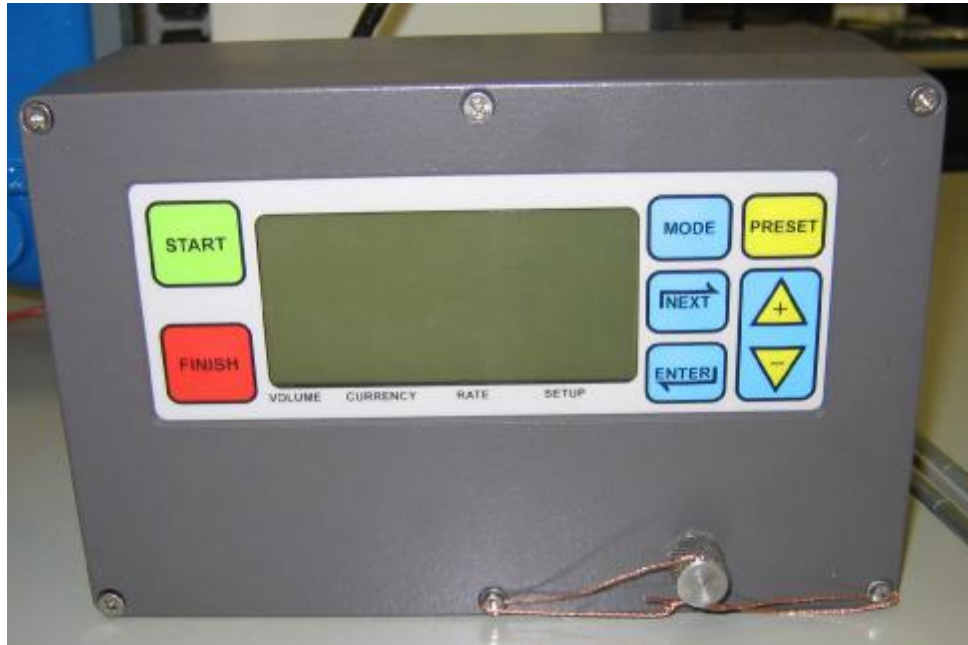

Figure 10 Remote display front panel showing method of sealing

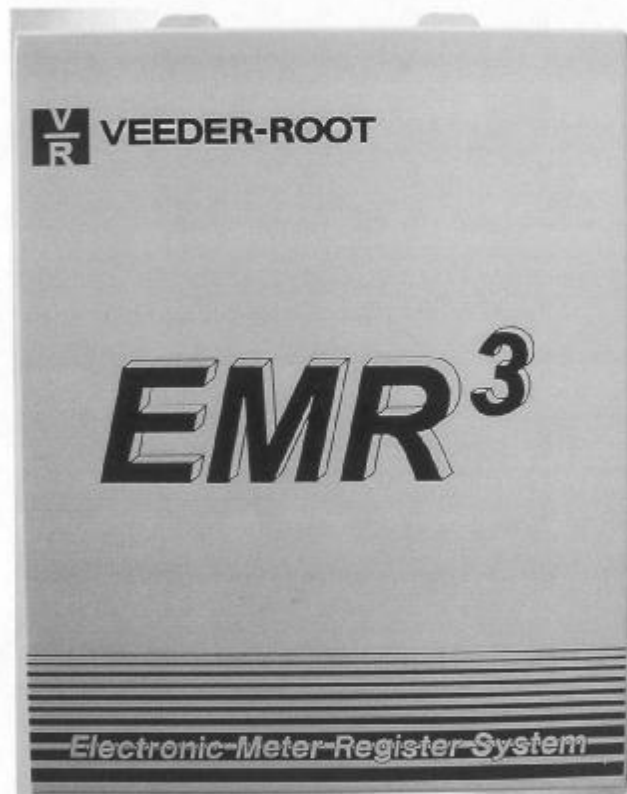

Figure 11 EMR³ Interconnect box (IB)

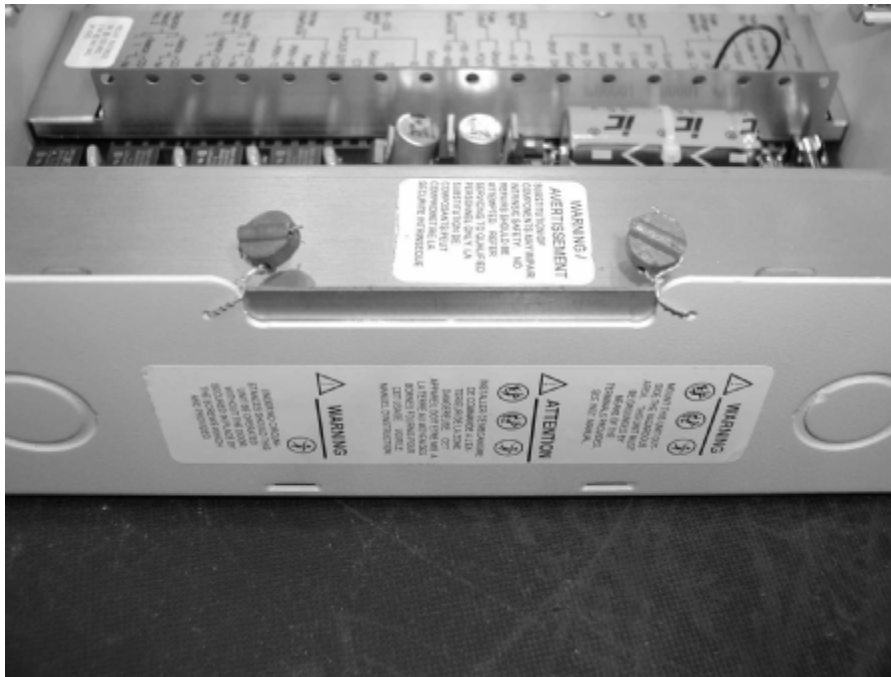

Figure 12 EMR3 interface box sealing

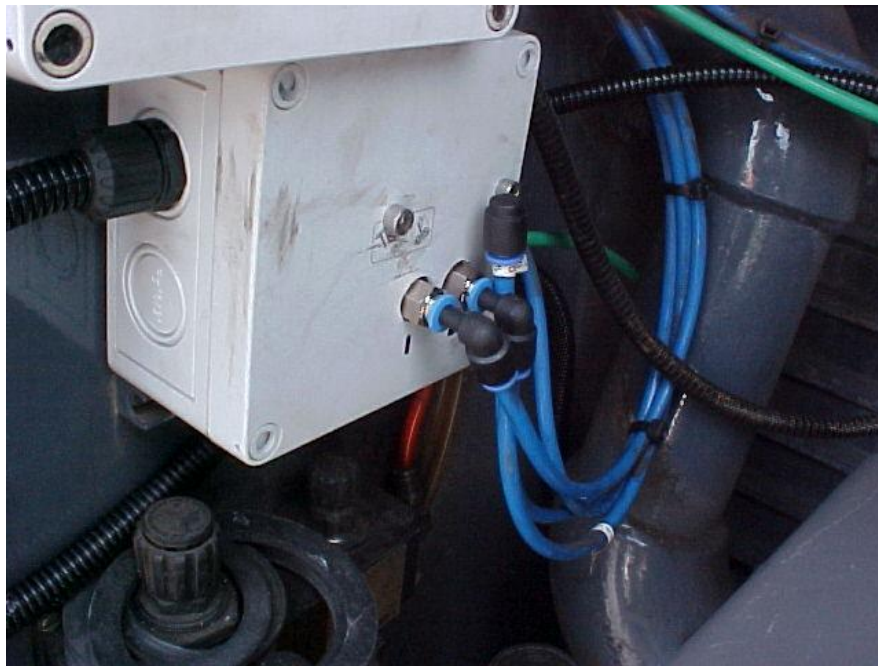

Figure 13 Pneumatic interface box

Price £10.00 net

©Crown Copyright 2007

NATIONAL WEIGHTS AND MEASURES LABORATORY

Department of Innovation, Universities and Skills

Printed in the UK for the Department of Innovation, Universities and Skills