

(UK/0126/0077)



MI-001

United Kingdom of Great Britain and Northern Ireland

## **Certificate of EC type-examination of a measuring instrument**

**Number: UK/0126/0077**

issued by the Secretary of State for Business, Innovation & Skills  
Notified Body Number 0126

In accordance with the requirements of the Measuring Instruments (Cold-water Meters) Regulations 2006 (SI 2006/1268) and the Measuring Instruments (Non-Prescribed Instruments) Regulations 2006 which implement, in the United Kingdom, Council Directive 2004/22/EC, this certificate of EC type-examination has been issued to:

**ABB Limited  
Oldends Lane  
Stonehouse  
Gloucestershire  
GL10 3TA  
United Kingdom**

in respect of a family of cold-water meters named AquaMaster, utilising a common, electromagnetic principle and having the following characteristics:

AquaMaster Mains Powered Model MM/GA, Size DN40, DN50, DN80,  
DN100, DN150, DN200, DN250 & DN300.  
AquaMaster Transmitter FER2  
 $Q_3/Q_1 (R) = 400$  or  $630$

The necessary data (principal characteristics, alterations, securing, functioning etc) for identification purposes and conditions (when applicable) are set out in the descriptive annex to this certificate.

A handwritten signature in black ink, appearing to read 'P R Dixon', is positioned above the printed name of the signatory.

Signatory: P R Dixon  
for Chief Executive  
National Weights & Measures Laboratory  
(Part of the National Measurement Office)  
Department for Business, Innovation & Skills  
Stanton Avenue  
Teddington  
Middlesex, TW11 0JZ  
United Kingdom

Issue Date: 26 April 2010  
Valid Until: 25 April 2020  
Reference No: T23/0017

# Descriptive Annex

## 1 INTRODUCTION

This pattern of liquid measuring instrument is for measuring the volume of cold water which has passed through it. It relates to models of the AquaMaster mains powered family based on an electromagnetic measurement principle.

## 2 FUNCTIONAL DESCRIPTION

The AquaMaster consists of two main elements, the flow transmitter (calculator/indicator) and the flow sensor (meter). The flow transmitter may be mounted on the sensor or positioned separately. (Figures 1 and 2).

## 3 TECHNICAL DATA

### 3.1 Flow designation

#### 3.1.1 Meters with Q3/Q1 (R400)

DN	Q4 (m3/h)	Q3 (m3/h)	Q2 (m3/h)	Q1 (m3/h)
40	31	25	0.1	0.063
50	50	40	0.16	0.1
80	125	100	0.4	0.25
100	200	160	0.64	0.4
150	500	400	1.6	1.0
200	788	630	2.5	1.6
250	1,250	1,000	4	2.5
300	2,000	1,600	6.4	4

**Table 1: Related flowrates according to DN**

#### 3.1.2 Meters with Q3/Q1 (R630)

DN	Q4 (m3/h)	Q3 (m3/h)	Q2 (m3/h)	Q1 (m3/h)
40	31	25	0.063	0.040
50	50	40	0.10	0.063
80	125	100	0.25	0.16
100	200	160	0.41	0.25
150	500	400	1.0	0.63
200	788	630	1.6	1.0
250	1,250	1,000	2.5	1.6
300	2,000	1,600	4.1	2.5

**Table 2: Related flowrates according to DN**

### 3.2 Other Designations

Temperature class:	T50 (0.1 °C – 50 °C)
Orientation requirements:	None
Maximum admissible pressure (MAP)	16 bar
Pressure Loss at Q3	0.25 bar max
Climatic environment:	-25 °C to +55 °C
Humidity	Condensing / non-condensing
Mechanical environment:	M1
Electromagnetic environment:	E1
Location:	Integral or Remote (<200m cable)
Reverse Flow:	Bi-directional measurement
Minimum straight length of inlet pipe:	0D (0)
Minimum straight length of outlet pipe:	0D (0)
Orientation:	Can be installed in any position
Power Supply:	Mains 85 to 265V AC Frequency 50Hz or 60Hz

#### 3.2.1 Software Versions

	Software i.d.	Software Version
Main Application	WAJC2027	v2.46
Bootloader	WAJC2009	V1.02
Update Application Manager (Non GSM Version)	WAJC2010	v1.04
Update Application Manager (GSM Version)	WAJC2026	V1.27
Pre Amp Sensor Memory	WAJC2004	V1.04
Pre-Amp EEROM	WAJC2033	V1.03

## 4 PERIPHERAL DEVICES AND INTERFACES

### 4.1 Interfaces

The instrument may have the following interfaces:

- (i) Digital Pulse output
- (ii) Scancoder Remote Reading Interface
- (iii) RS232 Communications
- (iv) Optional GSM Radio Communications
- (v) Optional Pressure Transducer Connection

## **4.2 Peripheral devices**

The instrument may be connected to any peripheral device that has been issued with a test certificate or parts certificate by a Notified Body responsible for Annex B (MI-001) under Directive 2004/22/EC in any Member State and bears the CE marking of conformity to the relevant directives; or

A peripheral device without a test certificate may be connected under the following conditions:

- it bears the CE marking for conformity to the EMC Directive;
- it is not capable of transmitting any data or instruction into the flow meter, other than to check for correct data transmission or validation / verification;
- Any Pulse / Frequency Output receiving equipment
- Alarm Contact Output receiving equipment
- RS232 communications equipment
- Scancoder reader via wired connection or an inductive pad

## **5 APPROVAL CONDITIONS**

The certificate is issued subject to the following conditions:

### **5.1 Legends and inscriptions**

#### **5.1.1 The instrument bears the following legends:**

‘CE’ marking  
Supplementary metrology marking  
Notified body identification number  
Accuracy class  
Serial number  
Manufacturers mark or name  
Certificate number  
Permanent flow rate  $Q_3$   
Flowrate range  $Q_3/Q_1$  (R)

### **5.2 Detail here the securing requirements.**

## **6 LOCATION OF SEALS AND VERIFICATION MARKS**

### **6.1 Securing the software**

After installation and commissioning, to prevent unauthorised modification of any parameters the “read-only” dip switch, must be set to On, which prevents login thereby making all parameters read only. This is as shown in Figures 3 and 4.

The “read only” mode works on all interfaces including the GSM / SMS communication option.

**6.2**            Sealing the transmitter

Anti tamper seals should be fitted, as shown in Figure 5.

**7**                **ALTERNATIVES**

There are no alternatives at present.

**8**                **ILLUSTRATIONS**

- Figure 1        AquaMaster Mains Powered Integral Form
- Figure 2        AquaMaster Mains Powered Remote Form
- Figure 3        Access to Read Only Switch
- Figure 4        Location and Setting of Read Only Switch
- Figure 5        Transmitter Sealing

**9**                **CERTIFICATE HISTORY**

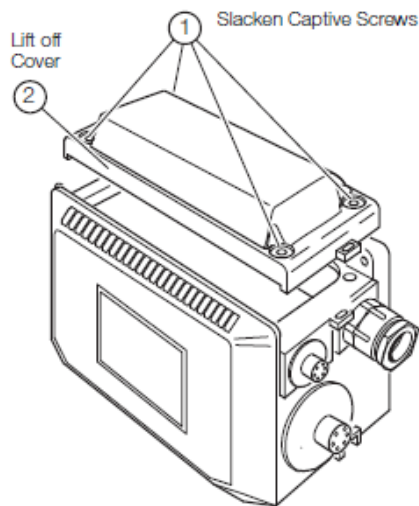
<b>ISSUE NO.</b>	<b>DATE</b>	<b>DESCRIPTION</b>
UK/0126/0077	26 April 2010	Type examination certificate first issued.



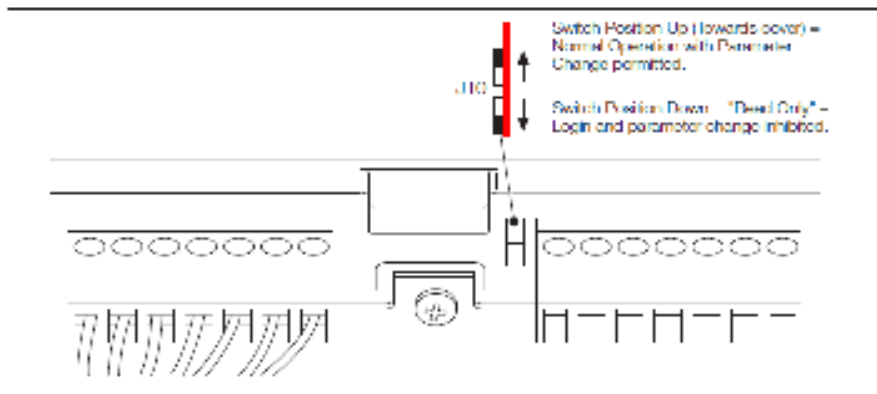
**Figure 1 AquaMaster Mains Powered Integral Form**



**Figure 2 AquaMaster Mains Powered Remote Form**

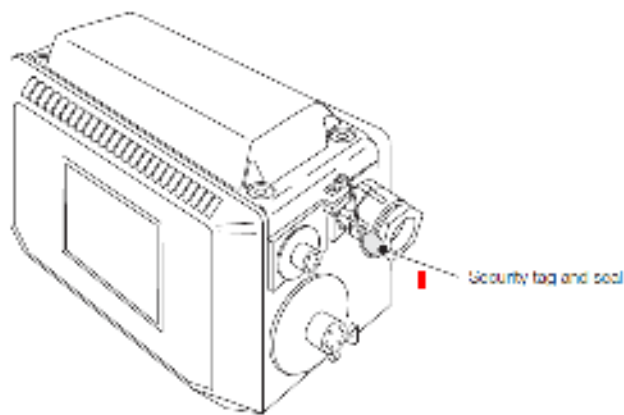


**Figure 3 Access to Read Only Switch**



*Fig. 3.17 Location of the Read Only switch*

**Figure 4 Location and Setting of the Read Only Switch**



**Figure 5 Transmitter Sealing**