

EC type-examination certificate UK/0126/0086 Revision 4

issued by:

**The National Measurement Office
Notified Body Number 0126**

In accordance with the requirements of the Measuring Instruments (Cold-Water Meters) Regulations 2006 (SI 2006/1268) and the Measuring Instruments (Non-Prescribed Instruments) Regulations 2006 which implement, in the United Kingdom, Council Directive 2004/22/EC, this EC type-examination certificate has been issued to:

**Elster Metering Limited
130 Camford Way
Sundon Park
Luton, Bedfordshire
LU3 3AN
United Kingdom**

in respect of a family of cold water meters utilising a common, volumetric measuring element and having the following characteristics:

A nominal capacity of 5.5 revs/litre
A rated permanent flowrate Q_3 of 10m³/h.

The necessary data (principal characteristics, alterations, securing, functioning etc) for identification purposes and conditions (when applicable) are set out in the descriptive annex to this certificate.

This revision replaces previous versions of the certificate.

**Issue Date: 25 October 2011
Valid Until: 26 July 2020
Reference No: TS02/003**



**Signatory: P R Dixon
for Chief Executive**



BIS

**Department for Business
Innovation & Skills**

Descriptive Annex

1 INTRODUCTION

This pattern of liquid measuring instrument is for measuring the volume of cold water which has passed through it. It relates to models of a semi-positive displacement cold-water meter having a Q_3 (permanent flowrate) value of 10 cubic metres per hour. It is based on a 5.5 revolutions per litre measuring chamber with model variations described in section 2. They are not designed to measure reverse flow.

2 FUNCTIONAL DESCRIPTION

2.1 V100 meter

The V100 meter (Figure 1) incorporates a 5.5 rev/l semi-positive displacement rotary piston measuring chamber and counter assembly mounted in a brass alloy body for connection into the water pipe via two G1½"A or G1¾"A male threaded connectors. The axis of the measuring chamber is parallel to the axis of the pipe, as shown in the cross sectional view Figure 2. The rotary piston drives a dog that couples to a roller wheel type register comprising eight wheels each circumferentially printed in contrasting colours with the digits 0 - 9. The first five wheels display whole cubic meters, the remaining three wheels display fractional cubic meters.

2.2 V200 meter

The V200 meter (Figure 3) has the measuring assembly fitted into a brass alloy body for in-line connection into the water pipe via two British G1¼"A, G1½"A G1¾"A or G2"A male pipe threaded connectors. The rotary piston driven magnet couples to a simple, mechanical non-resettable totalising register, a non-resettable totalising display incorporating an absolute encoder model register or a lithium cell powered electronic non-resettable totalising register. The electronic register features either an internal antenna, external antenna or externally wired serial or pulse output. Registers are positioned on the top of the measurement chamber housing and secured to the meter either by a plastic wrap around shroud riveted across its hinge and split line as shown in Figure 3 or a plastic snap fit shroud shown in Figure 18. Cross sectional views are shown in Figures 4 and 20.

3 TECHNICAL DATA

3.1 Flow Designation

3.1.1 Meters with $Q_3 = 10\text{m}^3/\text{h}$

Table 1 Permitted flow designation by model

Model Name	Q_3/Q_1 (R)				
	250	200	160	100	80
V100, V200	✓	✓	✓	✓	✓

Table 2 Related flowrates according to each Q₃/Q₁ designation

Q₃/Q₁ (R)	250	200	160	100	80
Q ₂ /Q ₁	1.6	1.6	1.6	1.6	1.6
Q ₁ Minimum flowrate (m ³ /h)	0.0400	0.0500	0.0625	0.1000	0.1250
Q ₂ Transitional flowrate (m ³ /h)	0.0640	0.0800	0.1000	0.1600	0.2000
Q ₃ Permanent flowrate (m ³ /h)	10	10	10	10	10
Q ₄ Overload flowrate (m ³ /h)	12.5	12.5	12.5	12.5	12.5

3.2 Register elements

Model Name	Register Variant	Volume of one revolution of the first display element (m³)	Verification Scale Interval (m³)	Indicating Range (m³)
V100	5x3 Register	0.01	0.0001	99999.9999
V200	Standard	0.001	0.00002	99999.99998
	Encoder	0.001	0.00002	9999.99998
	Electronic 6+5	0.0001	0.00001	999999.99999

3.3 Meter dimensions

Model Name	Register Variant	Overall Meter Dimensions (mm)			Meter Connection
		Diameter	Height	Length	
V100	5x3 Register	120	n/a	199, 260	G1½"A or G1¾"A
V200	Standard	151	145	199, 260	G1¼"A, G1½"A or G1¾"A
	Encoder		155		
	Electronic		155	300	

3.4 Other designations

Temperature class:	T30 (0.1°C – 30°C)
Orientation requirements:	None
Revs/litre of measuring chamber	5.5
Maximum admissible pressure (MAP)	16 bar
Pressure Loss at Q ₃	0.63 bar max
Climatic environment:	-10°C to +55°C
Humidity	Condensing / non-condensing.
Mechanical environment:	M1
Electromagnetic environment:	E1 (V200)
Location:	Open/closed
Reverse Flow:	Permitted but not measured
Software Version:	V02Txx (V200) where: Vxx: Controlled Metrological Code. Txx: Uncontrolled Non Metrological Code partly dependent on the output options..

4 PERIPHERAL DEVICES AND INTERFACES

4.1 Interfaces

The meters may have the following interfaces:

4.1.1 Reed switch sensor (V100 meter)

The meter register is equipped with a disc magnet on the first element of the verification scale. A reed switch sensor may be fitted in a pocket in close proximity to the magnet within the meter housing, as shown in Figure 5 and its lead connected to a remote pulse counting device. The lead's supply and return lines terminate either side of the normally open reed switch which closes when a magnetic pole is nearby, triggering a count in the device.

4.1.2 Inductive pointer and sensor unit (V200 meter)

A mechanical meter register is equipped with a metallic plated pointer (Figures 6 & 9) on the first element of the verification scale. Two bosses and two holes on the shroud enable optional inductive sensors to be fitted to it. A pulse is generated when the metallic pointer passes the inductive field of the sensor that may be transmitted to a remote counting device by a hard wired sensor similar to that shown in Figure 7 or accumulated in the memory of a radio transmitting sensor similar to that shown in Figure 19 and transferred on request to a receiving device. The manufacturer's name Elster is on the housing of the inductive sensor as well as the dial face

4.1.3 Reed switch sensor (V200 meter with wrap around shroud)

A mechanical meter register is equipped with a magnetic pointer on the first element of the verification scale. A reed switch sensor may be fitted to the meter shroud, as shown in Figures 11 and 12 and its lead connected to a remote pulse counting device. The lead's supply and return lines terminate either side of the normally open reed switch which closes when the magnet is near, triggering a count in the device. The manufacturer's name Elster is on the housing of the inductive sensor as well as the dial face.

4.1.4 Electronic register with radio output (V200 meter)

An electronic meter register factory fitted with an internal or external antenna for radio transmission of information to a receiving device. The radio may be factory set for operating in one way mode whereby the register transmits at regular intervals or in two way mode whereby the register transmits in response to a request from monitoring equipment.

4.1.5 Electronic register with encoder output (V200 meter)

An electronic meter register will send information via a factory fitted two wire touch readable serial port following the detection of a signal generated by a touch reader.

4.1.6 Electronic register with pulse output (V200 meter)

An electronic meter register equipped with a three wire flying lead comprising a reference ground line and two open drain pulse lines. The pulse scheme (width and weight) are programmed at manufacture.

5 APPROVAL CONDITIONS

The certificate is issued subject to the following conditions:

5.1 Legends and inscriptions

5.1.1 The instrument bears the following legends:

- 'CE' marking
- Supplementary metrology marking
- Notified body identification number
- Permanent flow rate Q_3
- Flowrate range Q_3/Q_1 (R)
- Serial number
- Manufacturers mark or name
- Certificate number
- Information in respect of conditions of use (where applicable)

6 LOCATION OF SEALS AND VERIFICATION MARKS

6.1 Location of markings and securing (sealing) arrangements.

6.1.1 V100

The serial number is marked adjacent to the register window of the meter housing and the verification marks are engraved on the central joint face of the meter housing, as shown in Figure 5.

A sealing wire links the two halves of the body and is secured with a lead seal, also shown in Figure 5.

6.1.2 V200 (Screw Ring Security)

A register is positioned above a bossed pressure plate by a shroud whose internal clips engage a groove on the outside of the boss as shown in Figures 4 and 20. A screw ring clamps the pressure plate to the meter body which is secured by a lead seal crimped on to the free ends of a sealing wire looped through a hole in the body's web and a radial lug on the screw ring as shown in Figure 3.

6.1.3 V200 (Plastic wrap around shroud)

The serial number and verification markings are permanently etched on the top surface of the shroud as shown in Figures 6 (mechanical register), 13, 14 and 15 (electronic registers).

The wrap around shroud with its internal clips engaged in the groove of the pressure plate boss (Figure 4) is fixed in the closed position by hollow riveting its hinge and split points. A lead seal secures the free ends of a sealing wire looped through two adjacent holes at the split point as seen in Figure 3. The shroud can not be removed without showing visible signs of unauthorised entry if attempted.

6.1.4 V200 (Plastic snap fit shroud)

The serial number and verification markings are permanently etched on the top surface of the shroud in a location that will remain visible if a sensor is attached, as shown in Figures 18 and 19.

The meter is secured once the shroud has been pressed over the pressure plate boss and its clips have engaged in the annular groove (Figure 20). The shroud cannot be removed without showing visible signs of unauthorised entry if attempted.

6.1.5 V100 Alternative Markings Arrangement - Laser etched lid

The meter is fitted with a larger lid and the serial number and verification marks are laser etched on to it (Figure 21). The lid is secured to the meter body using a sealing wire (Figure 22).

7 ALTERNATIVES

7.1 Inductive Pointer

Having an inductive pointer with a stainless steel insert as shown in Figure 10.

7.2 Alternative Register

Having a mechanical register equipped with an inductive pointer on the first element of the verification scale, enclosed in a copper can and driven by the same magnetic coupling system described in section 2.2. The register is available with a partially transparent dial face as that shown in Figure 16 or a fully opaque dial face as shown in Figure 18. The position of an optional inductive sensor on a wrap around shroud is shown in Figure 17.

8

ILLUSTRATIONS

- Figure 1 V100 meter.
- Figure 2 Sectional view of V100 meter.
- Figure 3 V200 meter.
- Figure 4 Sectional view of V200 meter.
- Figure 5 View showing position of V100 reed switch sensor, markings and securing method.
- Figure 6 V200 meter dial markings.
- Figure 7 Inductive Sensor mounted on a V200 meter shroud.
- Figure 8 V200 Dial Face, showing position of Inductive Sensor.
- Figure 9 V200 Metallic Plated Inductive Pointer.
- Figure 10 V200 Stainless Steel Insert Inductive Pointer .
- Figure 11 Reed Switch Sensor mounted on a V200 meter shroud.
- Figure 12 V200 Dial Face showing position of Reed Switch Sensor.
- Figure 13 V200 Electronic Register with Radio Output..
- Figure 14 V200 Electronic Register with Encoder Output.
- Figure 15 V200 Electronic Register with Pulse Output.
- Figure 16 V200 Alternative register.
- Figure 17 V200 Position of Inductive Sensor with Alternative register.
- Figure 18 V200 with Alternative Snap Fit Shroud.
- Figure 19 Alternative Snap Fit Shroud with Inductive Sensor.
- Figure 20 Sectional View of a V200 Meter with Alternative Snap Fit Shroud.
- Figure 21 V100 Alternative Markings Arrangement - Laser etched lid.
- Figure 22 Sealing of V100 Larger Lid with Laser etched markings

CERTIFICATE HISTORY

ISSUE NO.	DATE	DESCRIPTION
UK/0126/0086	27 th July 2010	Type examination certificate first issued.
UK/0126/0086 Revision 1	22 nd October 2010	Section 3.2 Added V200 300mm x G2" Section 3.4 Added qualification for software version. Section 4. Added Descriptions of Electronic Outputs:- 4.4: Radio; 4.5: Encoder; 4.6: Pulse. Section 7.2 - Added Alternative register. Figures: Re-organised, added pictures of V200 Dial Face, Electronic Register Shroud Faces and updated Markings, adjusted sectional diagrams General: Editorial changes.
UK/0126/0086 Revision 2	3 rd February 2011	Section 2.2 Added G2"A to available thread sizes. Section 6.2.2. - Amended to describe two wire and lead seal securing devices. Figure 3 - Replaced to illustrate both securing devices. General: Editorial changes.
UK/0126/0086 Revision 3	21 st July 2011	Section 2.2: Added Snap Fit Shroud Table 3.2 Corrected Section 3.4 Location: removed repeat of condensing/non-condensing Section 4.1.2: Added radio version of inductive sensor. Sections 4.1.3: Qualified as wrap around shroud. Section 6.1: Reorganised, separated Screw ring and wrap around shroud security, added snap fit shroud's description. Section 7.2: Reference 2.2 was 2.1. Added opaque register. Figures: 2, Errors in part list corrected 3, Replaced 8, 12 & 17 Sensor outlines coloured. 18, 19 & 20 added.
UK/0126/0086 Revision 4	25 October 2011	Section 6.1.5 - V100 Alternative Markings Arrangement - Laser etched lid added, associated Figures 21 and 22 added.



Figure 1 V100 Meter

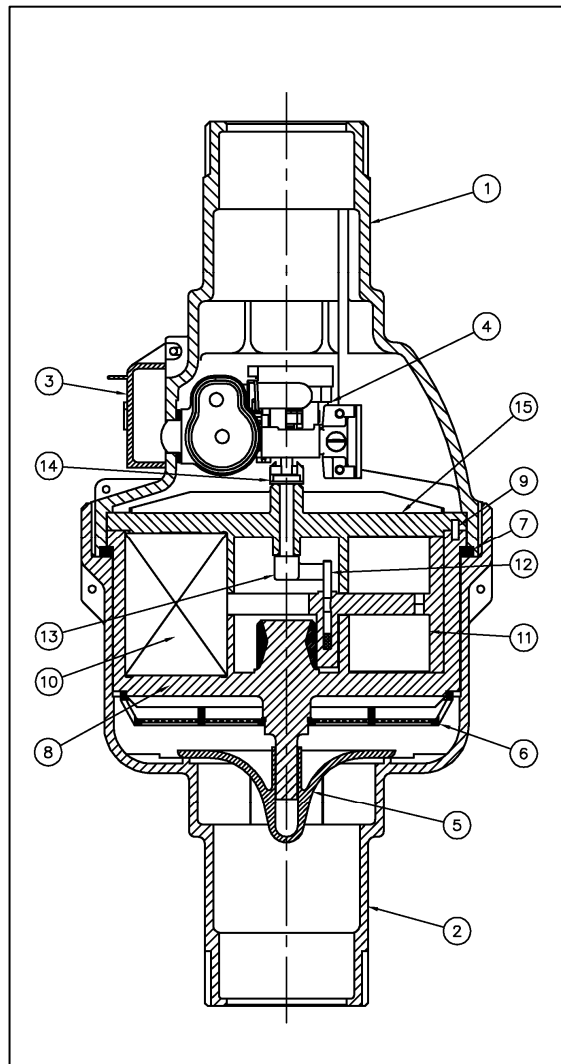

ITEM	DESCRIPTION	ITEM	CHAMBER ASSEMBLY
1	COUNTER HOUSING	8	CHAMBER AND THIMBLE
2	CHAMBER HOUSING	9	LOCATING PIN
3	LID	10	SHUTTER
4	COUNTER ASSEMBLY	11	PISTON
5	RETURN FLOW RESTRICTOR	12	PISTON PIN
6	STRAINER	13	DRIVE BAR
7	'O' RING SEAL	14	DRIVE SPINDLE
		15	TOP PLATE

Figure 2 Sectional view of V100 meter



Figure 3 V200 Meter

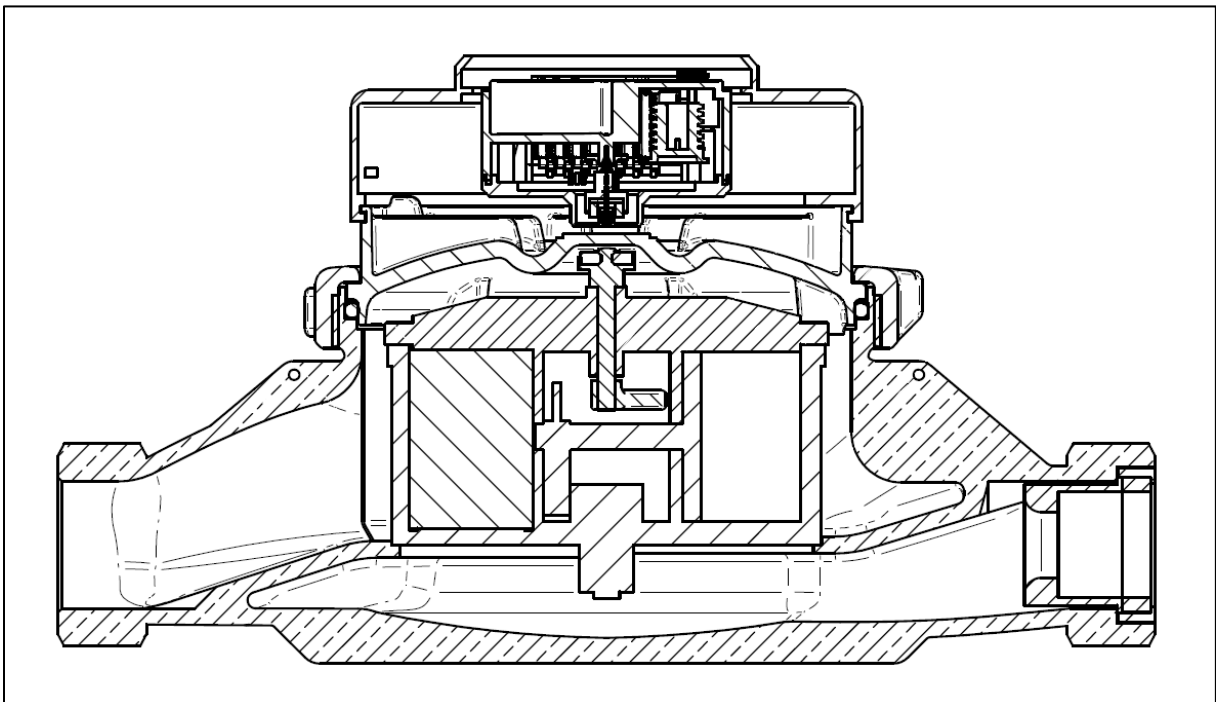

Figure 4 Sectional View of a V200 Meter

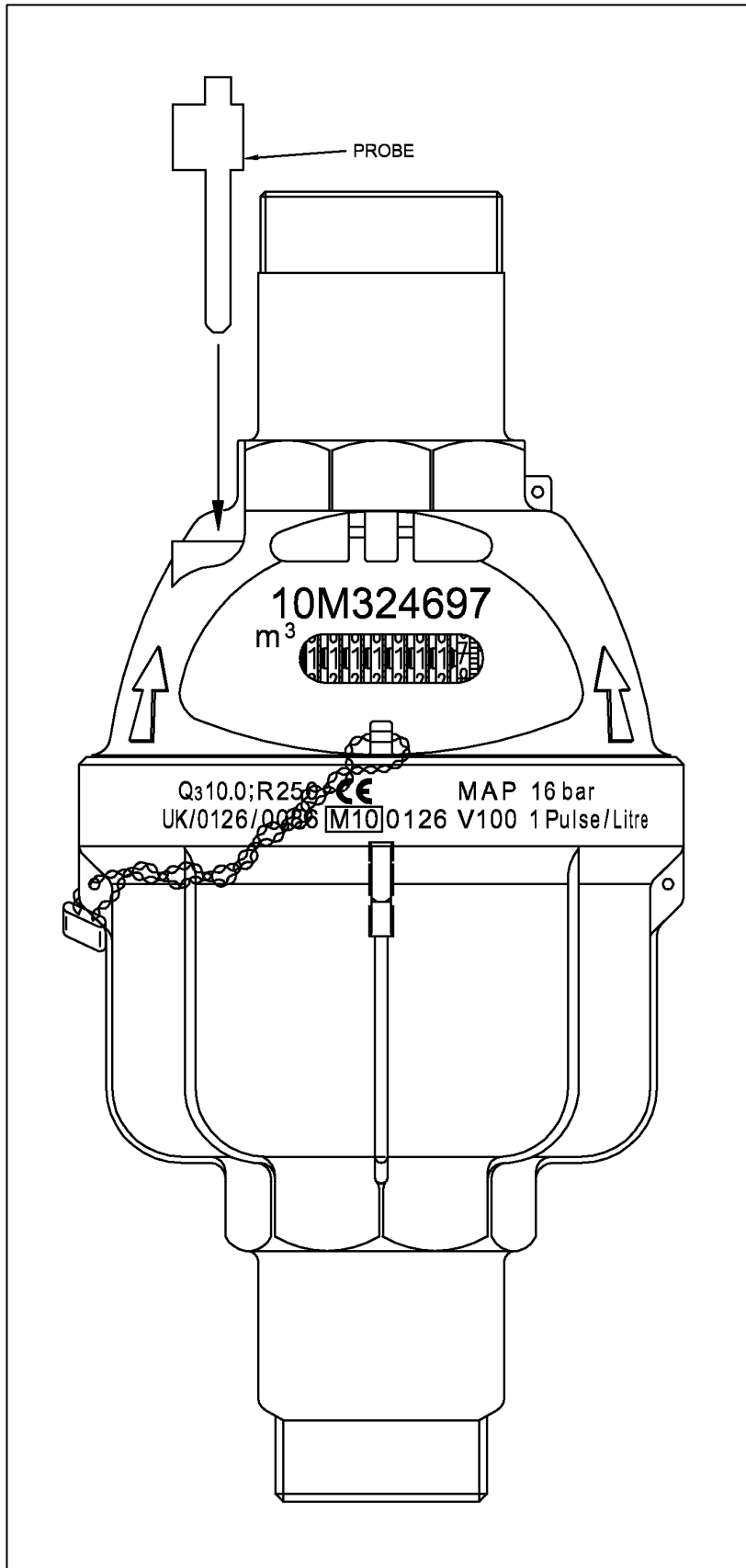

Figure 5 View showing position of V100 reed switch sensor, markings and securing method

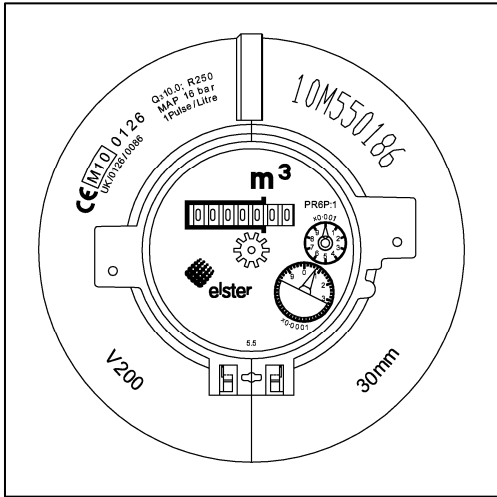

Figure 6 V200 Meter Dial Markings



Figure 7 Inductive Sensor mounted on a V200 meter shroud

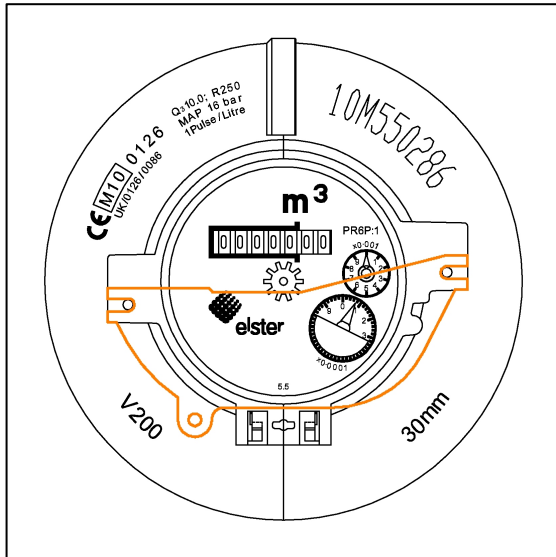

Figure 8 V200 Dial Face showing position of Inductive Sensor

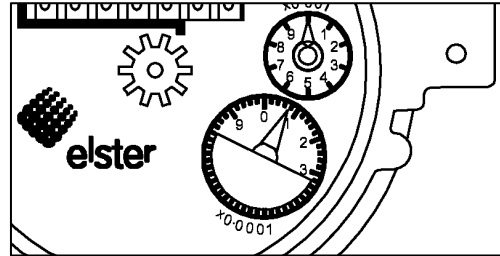

Figure 9 Metallic Plated Inductive Pointer

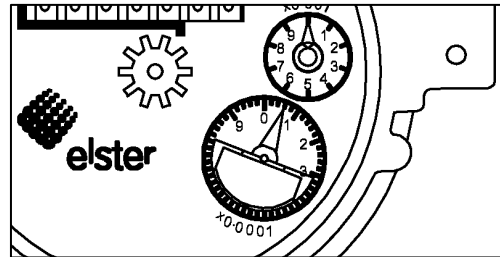

Figure 10 Stainless Steel Insert Inductive Pointer



Figure 11 Reed Switch Sensor mounted on a V200 meter shroud.

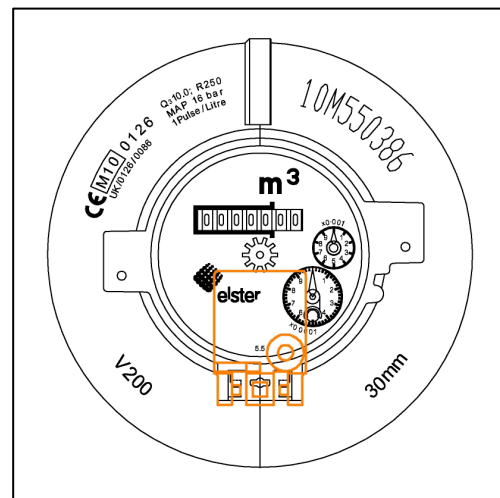

Figure 12 V200 dial face showing position of Reed Switch Sensor



Figure 16 V200 Alternative register

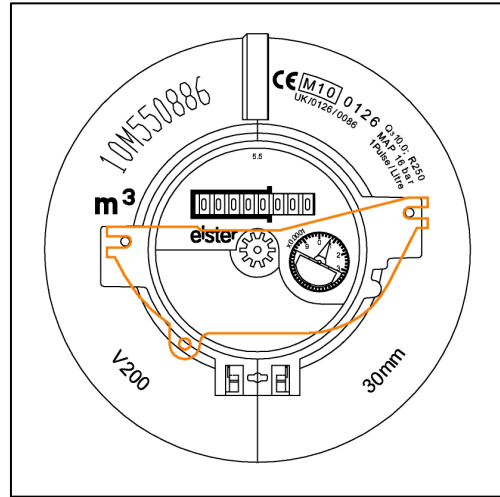

Figure 17 V200 Position of Inductive Sensor with Alternative register



Figure 18 V200 with Alternative Snap Fit Shroud

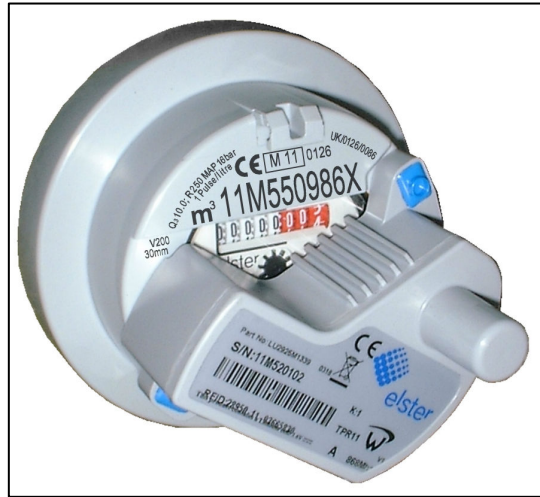

Figure 19 Alternative Snap Fit Shroud with Inductive Sensor

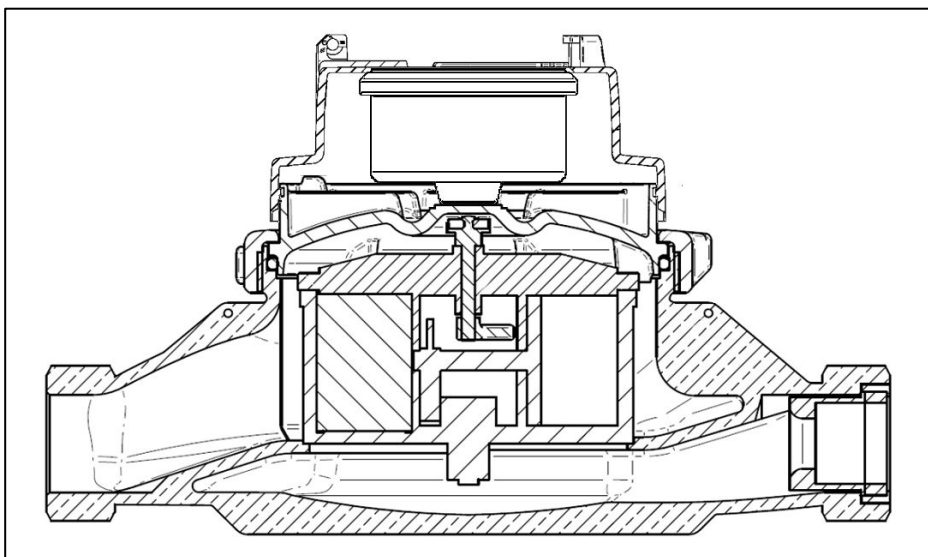

Figure 20 Sectional View of a V200 Meter with Alternative Snap Fit Shroud



Figure 21 V100 Alternative Markings Arrangement - Laser etched lid



Figure 22 Sealing of V100 Larger Lid with Laser etched markings