



**EC type-examination certificate
UK/0126/0087**

issued by:

**The National Measurement Office
Notified Body Number 0126**

In accordance with the requirements of the Measuring Instruments (Cold-Water Meters) Regulations 2006 (SI 2006/1268) and the Measuring Instruments (Non-Prescribed Instruments) Regulations 2006 which implement, in the United Kingdom, Council Directive 2004/22/EC, this EC type-examination certificate has been issued to:

**Elster Metering Limited
130 Camford Way
Sundon Park
Luton, Bedfordshire
LU3 3AN
United Kingdom**

in respect of a family of cold water meters utilising a common, volumetric measuring element and having the following characteristics:

A nominal capacity of 3.25 revs/litre
A rated permanent flowrate Q_3 of 10m³/hr or 16m³/hr.

The necessary data (principal characteristics, alterations, securing, functioning etc) for identification purposes and conditions (when applicable) are set out in the descriptive annex to this certificate.

**Issue Date: 26 May 2011
Valid Until: 25 May 2021
Reference No: TS02/0004**

**Signatory: P R Dixon
for Chief Executive**



BIS

**Department for Business
Innovation & Skills**

Descriptive Annex

1 INTRODUCTION

This pattern of liquid measuring instrument is for measuring the volume of cold water which has passed through it. It relates to models of a semi-positive displacement cold-water meter having a Q_3 (permanent flowrate) value of 10 or 16 cubic metres per hour. It is based on a 3.25 revolutions per litre measuring chamber with model variations described in section 2. They are not designed to measure reverse flow.

2 FUNCTIONAL DESCRIPTION

2.1 V100 meter

The V100 meter (Figure 1) incorporates a 3.25 rev/l semi-positive displacement rotary piston measuring chamber and counter assembly mounted in a brass alloy body for connection into the water pipe via two G2"A male threaded connectors. The axis of the measuring chamber is parallel to the axis of the pipe, as shown in the cross sectional view Figure 2. The rotary piston drives a dog that couples to a roller wheel type register comprising eight wheels, each circumferentially printed with the digits 0 - 9. The first five wheels display whole cubic meters, the remaining three wheels display decimal fractions of cubic meters.

2.2 V200 meter

The V200 meter (Figure 2) has the measuring assembly fitted into a brass alloy body for in-line connection into the water pipe via two British G2"A male pipe threaded connectors. The rotary piston driven magnet couples to a simple, mechanical non-resettable totalising register (Figure 8), a non-resettable totalising display incorporating an absolute encoder model register or a lithium cell powered electronic non-resettable totalising register. The electronic register (Figure 10) features either an internal antenna, external antenna or externally wired serial or pulse output. Registers are positioned on the top of the measurement chamber housing and secured to the meter by a plastic wrap around shroud riveted across its hinge and split line. A cross sectional view is shown in Figure 4.

3 TECHNICAL DATA

3.1 Flow Designation

3.1.1 Meters with $Q_3 = 10\text{m}^3/\text{hr}$

Table 1 Permitted flow designation by model

Model Name	Q_3/Q_1 (R)
	80
V100, V200	✓

Table 2 Related flowrates according to each Q₃/Q₁ designation

Q₃/Q₁ (R)	80
Q ₂ /Q ₁	1.6
Q ₁ Minimum flowrate (m ³ /h)	0.1250
Q ₂ Transitional flowrate (m ³ /h)	0.2000
Q ₃ Permanent flowrate (m ³ /h)	10
Q ₄ Overload flowrate (m ³ /h)	12.5

3.1.2 Meters with Q₃ = 16 m³/hr

Table 3 Permitted flow designation by model

Model Name	Q ₃ /Q ₁ (R)			
	200	160	100	80
V100	✓	✓	✓	✓

Table 4 Related flowrates according to each Q₃/Q₁ designation

Q₃/Q₁ (R)	200	160	100	80
Q ₂ /Q ₁	1.6	1.6	1.6	1.6
Q ₁ Minimum flowrate (m ³ /h)	0.0800	0.1000	0.1600	0.2000
Q ₂ Transitional flowrate (m ³ /h)	0.1280	0.1600	0.2560	0.3200
Q ₃ Permanent flowrate (m ³ /h)	16	16	16	16
Q ₄ Overload flowrate (m ³ /h)	20	20	20	20

3.2 Register elements

Model Name	Register Variant	Volume of one revolution of the first display element (m ³)	Verification Scale Interval (m ³)	Indicating Range (m ³)
V100	5x3 register	0.01	0.0001	99999.9999
V200	Standard	0.001	0.00002	99999.99998
	Encoder	0.001	0.00002	9999.99998
	Electronic 6+5	0.00001	0.00001	999999.99999

3.3 Meter dimensions

Model Name	Register Variant	Overall Meter Dimensions (mm)			Meter Connection
		Diameter	Height	Length	
V100	5x3 Register	152	n/a	225, 300	G2"A
V200	Standard	181	166	300	G2"A
	Encoder		176		
	Electronic		176		

3.4 Other designations

Temperature class:	T30 (0.1°C – 30°C)
Orientation requirements:	None
Revs/litre of measuring chamber	3.25
Maximum admissible pressure (MAP)	16 bar
Pressure Loss at Q3	0.63 bar max
Climatic environment:	-10°C to +55°C
Humidity	Condensing / non-condensing.
Mechanical environment:	M1
Electromagnetic environment:	E1 (V200)
Location:	Open/closed, condensing/non-condensing
Reverse Flow:	Permitted but not measured
Software Version	V02Txx (V200) where: Vxx: Controlled Metrological Code. Txx: Uncontrolled Non Metrological Code.

4 PERIPHERAL DEVICES AND INTERFACES

4.1 Interfaces

The meters may have the following interfaces:

4.1.1 Reed switch sensor (V100 meter)

The meter register is equipped with a disc magnet on the first element of the verification scale. A reed switch sensor may be fitted in a pocket in close proximity to the magnet within the meter housing, as shown in Figure 5 and its lead connected to a remote pulse counting device. The lead's supply and return lines terminate either side of the normally open reed switch which closes when a magnetic pole is nearby, triggering a count in the device.

4.1.2 Inductive pointer and sensor unit (V200 meter)

A mechanical meter register is equipped with a metallic plated pointer (Figure 6) on the first element of the verification scale. Two bosses and two holes on the shroud enable the option of an inductive sensor to be fitted to the meter shroud as shown in Figures 7 and 8. A pulse is generated when the metallic pointer passes the inductive field of the sensor that may be transmitted by wire to a remote counting device. The manufacturer's name Elster is on the housing of the inductive sensor as well as the dial face.

4.1.3 Reed switch sensor (V200 meter)

A mechanical meter register is equipped with a magnetic pointer on the first element of the verification scale. A reed switch sensor may be fitted to the meter shroud, as shown in Figures 11 and 12 and its lead connected to a remote pulse counting device. The lead's supply and return lines terminate either side of the normally open reed switch which closes when the magnet is near, triggering a count in the device. The manufacturer's name Elster is on the housing of the inductive sensor as well as the dial face.

4.1.4 Electronic register with radio output (V200 meter)

An electronic meter register factory fitted with an internal or external antenna for radio transmission of information to a receiving device. The radio may be factory set for operating in one way mode whereby the register transmits at regular intervals or in two way mode whereby the register transmits in response to a request from monitoring equipment.

4.1.5 Electronic register with encoder output (V200 meter)

An electronic meter register will send information via a factory fitted two wire touch readable serial port following the detection of a signal generated by a touch reader.

4.1.6 Electronic register with pulse output (V200 meter)

An electronic meter register equipped with a three wire flying lead comprising a reference ground line and two open drain pulse lines. The pulse scheme (width and weight) are programmed at manufacture.

5 APPROVAL CONDITIONS

The certificate is issued subject to the following conditions:

5.1 Legends and inscriptions

5.1.1 The instrument bears the following legends:

- 'CE' marking
- Supplementary metrology marking
- Notified body identification number
- Permanent flow rate Q_3
- Flowrate range Q_3/Q_1 (R)
- Serial number
- Manufacturers mark or name
- Certificate number
- Information in respect of conditions of use (where applicable)

6 LOCATION OF SEALS AND VERIFICATION MARKS

6.1 Location of markings and securing (sealing) arrangements.

6.1.1 V100

The serial number is marked adjacent to the register window of the meter housing and the verification marks are engraved on the central joint face of the meter housing. A sealing wire links the two halves of the body and is secured with a lead seal. Details are shown in Figure 5.

6.1.2 V200

The serial number and verification markings are permanently etched on the top surface of the shroud as shown in Figures 6 (mechanical register), 13, 14 and 15 (electronic registers).

Two lead seals secure the free ends of two sealing wires as seen in Figure 3. One wire is looped through holes in a body web and a radial lug on the screw ring, the second is looped through two adjacent holes at the split point on a wrap around shroud. The screw ring clamps a bossed pressure plate to the meter body. A register is positioned above the boss by the wrap around shroud which, on closing engages its internal annular lip into an outer annular groove on the boss as shown in Figure 4. The shroud is fixed in the closed position by hollow riveting its hinge and split points. Neither the shroud nor the screw ring can be removed without showing visible signs of unauthorised entry if attempted.

7 ALTERNATIVES

7.1 Inductive Pointer

Having an inductive pointer with a stainless steel insert (Figure 10).

7.2 Alternative Register

Having a mechanical register equipped with an inductive pointer on the first element of the verification scale enclosed in a copper can, as shown in Figure 16 and driven by the same magnetic coupling system described in section 2.1. The position of an optional inductive sensor is shown in Figure 17.

8 ILLUSTRATIONS

- Figure 1 V100 meter
- Figure 2 Sectional view of V100 meter.
- Figure 3 V200 meter
- Figure 4 Sectional view of V200 meter.
- Figure 5 View showing position of V100 reed switch sensor, markings and securing method
- Figure 6 V200 meter dial markings.
- Figure 7 Inductive Sensor mounted on a V200 meter shroud
- Figure 8 V200 Dial Face, showing position of Inductive Sensor.
- Figure 9 V200 Metallic Plated Inductive Pointer
- Figure 10 V200 Stainless Steel Insert Inductive Pointer
- Figure 11 Reed Switch Sensor mounted on a V200 meter shroud
- Figure 12 V200 Dial Face showing position of Reed Switch Sensor
- Figure 13 V200 Electronic Register with Radio Output.
- Figure 14 V200 Electronic Register with Encoder Output.
- Figure 15 V200 Electronic Register with Pulse Output.
- Figure 16 V200 Alternative Register.
- Figure 17 V200 Position of Inductive Sensor with Alternative register.

9

CERTIFICATE HISTORY

ISSUE NO.	DATE	DESCRIPTION
UK/0126/0087	26 May 2011	Type examination certificate first issued.



Figure 1 V100

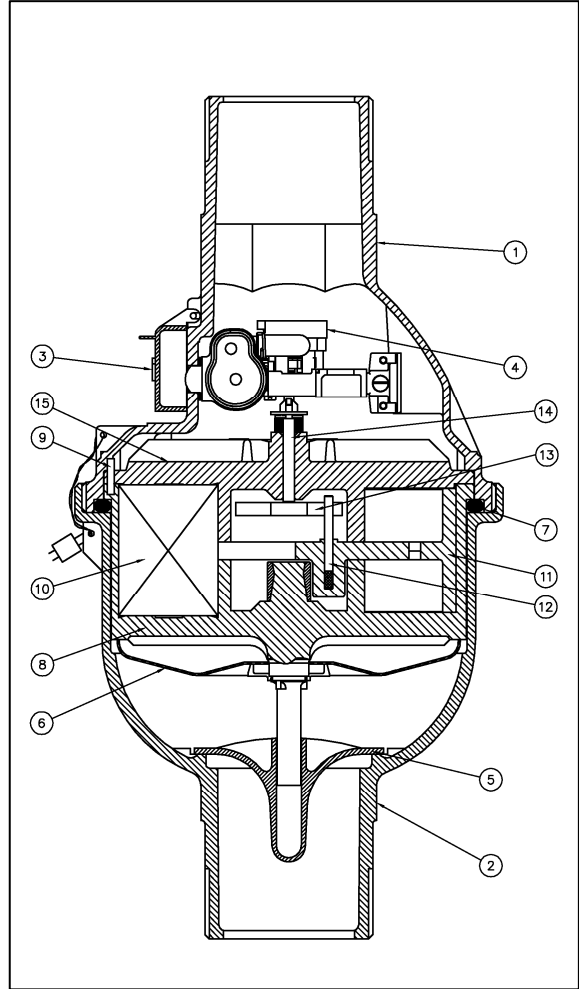

ITEM	DESCRIPTION	ITEM	CHAMBER ASSEMBLY
1	COUNTER HOUSING	8	CHAMBER AND THIMBLE
2	CHAMBER HOUSING	9	LOCATING PIN
3	LID	10	SHUTTER
4	COUNTER ASSEMBLY	11	PISTON
5	RETURN FLOW RESTRICTOR	12	PISTON PIN
6	STRAINER	13	DRIVE BAR
7	O' RING SEAL	14	DRIVE SPINDLE
		15	TOP PLATE

Figure 2 Sectional view of V100 meter



Figure 3 V200 meter

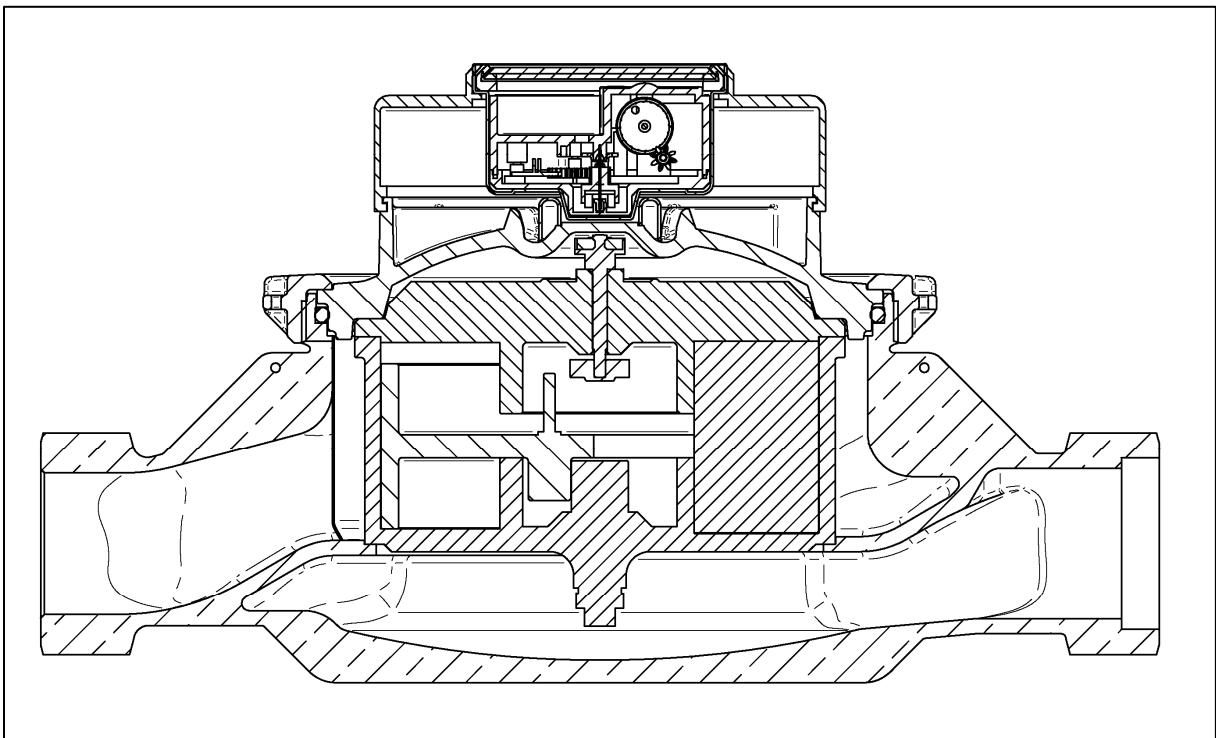

Figure 4 Sectional view of V200 meter

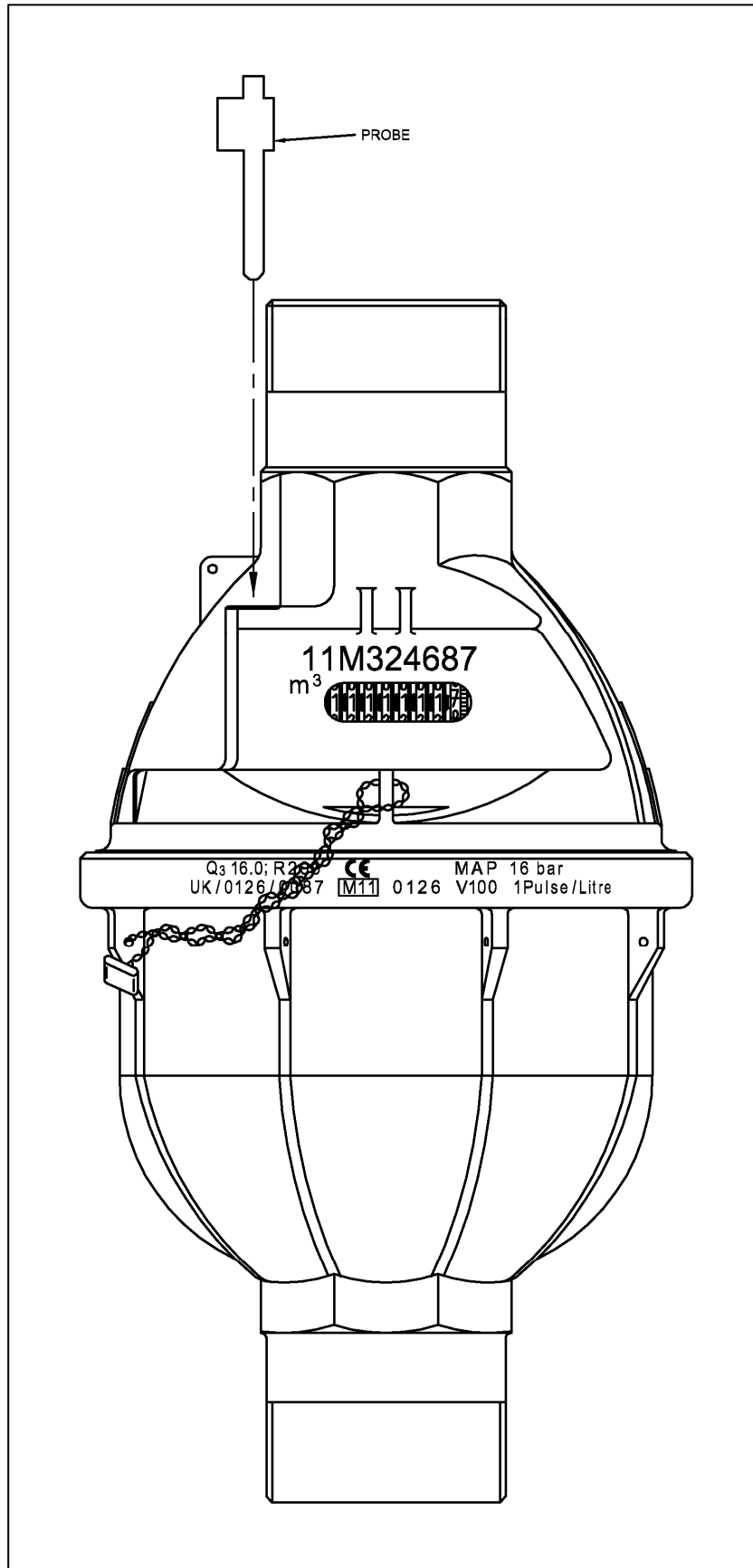

Figure 5 View showing position of V100 reed switch sensor, markings and securing method

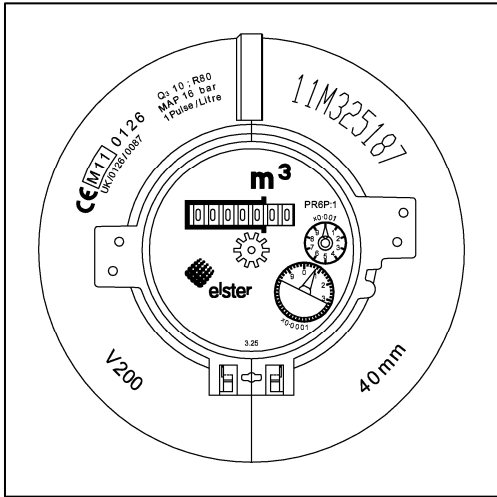

Figure 6 V200 meter dial markings



Figure 7 Inductive Sensor mounted on a V200 meter shroud

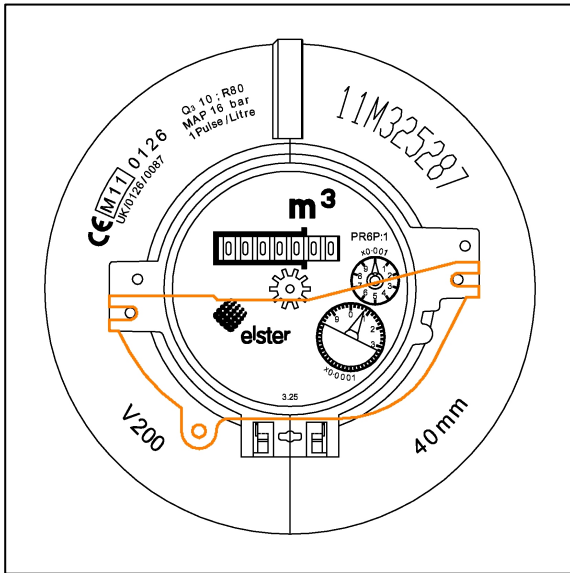

Figure 8 V200 Dial Face showing position of Inductive Sensor

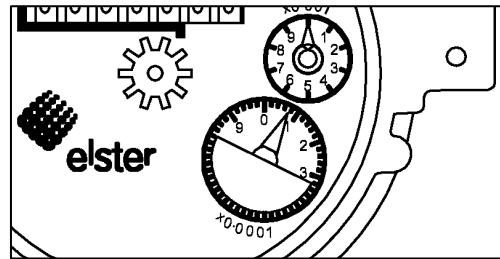

Figure 9 V200 Metallic Plated Inductive Pointer

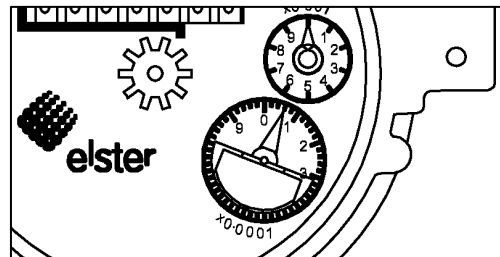

Figure 10 V200 Stainless Steel Insert Inductive Pointer



Figure 11 Reed Switch Sensor mounted on a V200 meter shroud.

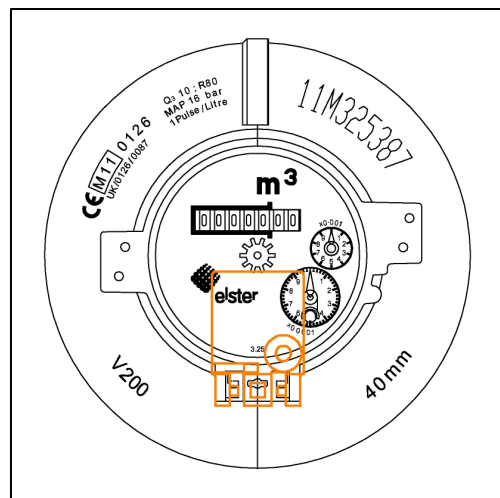
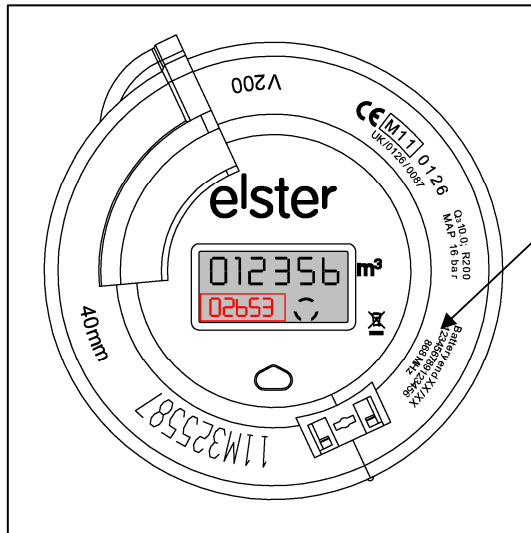

Figure 12 V200 dial face showing position of Reed Switch Sensor



Printing of the Radio Address is optional

Figure 13 V200 Shroud Markings of Electronic Register with Radio Output

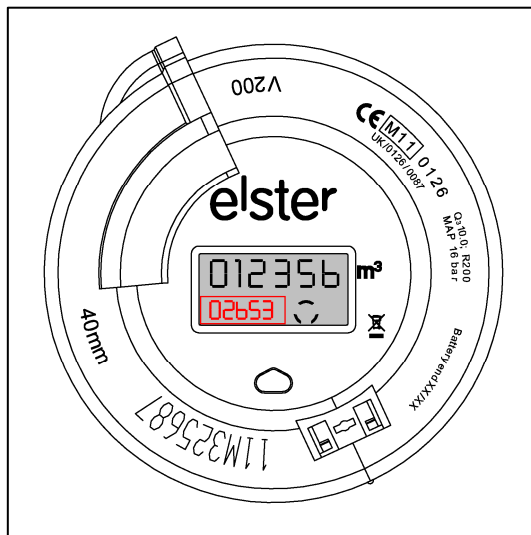
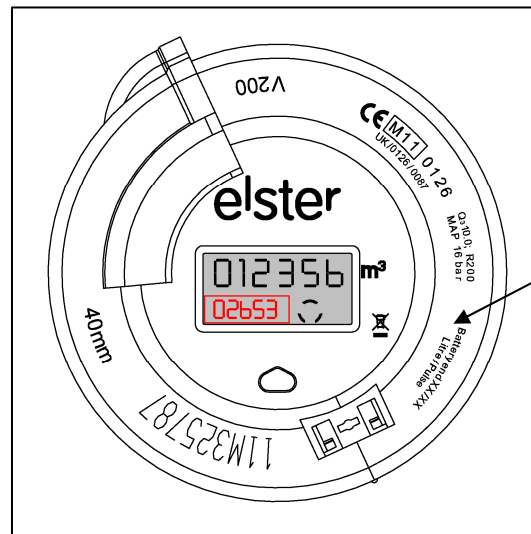

Figure 14 V200 Shroud Markings of Electronic Register with Encoder Output



Pulse Weight

Figure 15 V200 Shroud Markings of Electronic Register with Pulse Output



Figure 16 V200 Alternative register

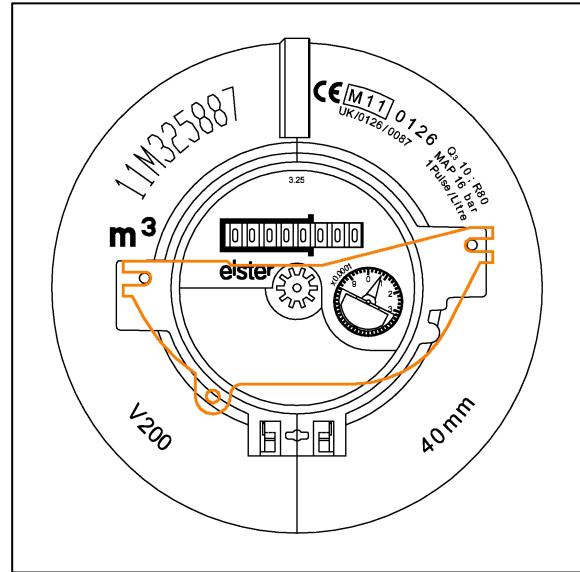

Figure 17 V200 Position of Inductive Sensor with Alternative register