

EC type-examination certificate UK/0126/0102 Revision 1

issued by:

**The National Measurement Office
Notified Body Number 0126**

In accordance with the requirements of the Measuring Instruments (Cold-water Meters) Regulations 2006 (SI 2006/1268) and the Measuring Instruments (Non-Prescribed Instruments) Regulations 2006 which implement, in the United Kingdom, Council Directive 2004/22/EC, this certificate of EC type-examination has been issued to:

**ABB Limited
Oldends Lane
Stonehouse
Gloucestershire
GL10 3TA
United Kingdom**

in respect of a family of cold-water meters named AquaMaster, utilising a common, electromagnetic principle and having the following characteristics:

AquaMaster 3 Mains Powered Model MM/GA or FER2.
Size DN40, DN50, DN80, DN100, DN125, DN150, DN200, DN250 & DN300.
AquaMaster Transmitter FET2
Q3/Q1 (R) = 400 or 630

The necessary data (principal characteristics, alterations, securing, functioning etc) for identification purposes and conditions (when applicable) are set out in the descriptive annex to this certificate.

This Revision replaces previous versions of this certificate

Issue Date: 02 August 2011
Valid Until: 24 March 2021
Reference No: TS02/0001

Signatory: P R Dixon
for Chief Executive



BIS

**Department for Business
Innovation & Skills**

Descriptive Annex

1 INTRODUCTION

This pattern of liquid measuring instrument is for measuring the volume of cold water which has passed through it. It relates to models of the AquaMaster 3 mains powered family based on an electromagnetic measurement principle.

2 FUNCTIONAL DESCRIPTION

The AquaMaster consists of two main elements, the flow transmitter (calculator/indicator) and the flow sensor (meter). The flow transmitter may be mounted on the sensor or positioned separately (Figures 1 and 2).

3 TECHNICAL DATA

3.1 Flow designation

3.1.1 Meters with Q3/Q1 (R400)

DN	Q4 (m3/h)	Q3 (m3/h)	Q2 (m3/h)	Q1 (m3/h)
40	31	25	0.1	0.063
50	50	40	0.16	0.1
80	125	100	0.4	0.25
100	200	160	0.64	0.4
125	200	160	0.64	0.4
150	500	400	1.6	1.0
200	788	630	2.5	1.6
250	1,250	1,000	4	2.5
300	2,000	1,600	6.4	4

Table 1: Related flowrates according to DN

3.1.2 Meters with Q3/Q1 (R630)

DN	Q4 (m3/h)	Q3 (m3/h)	Q2 (m3/h)	Q1 (m3/h)
40	31	25	0.063	0.040
50	50	40	0.10	0.063
80	125	100	0.25	0.16
100	200	160	0.41	0.25
125	200	160	0.41	0.25
150	500	400	1.0	0.63
200	788	630	1.6	1.0
250	1,250	1,000	2.5	1.6
300	2,000	1,600	4.1	2.5

Table 2: Related flowrates according to DN

3.2 Other Designations

Temperature class:	T50 (0.1 °C – 50 °C)
Orientation requirements:	None
Maximum admissible pressure (MAP)	16 bar
Pressure Loss at Q3	0.63 bar max
Climatic environment:	-25 °C to +55 °C
Humidity	Condensing / non-condensing
Mechanical environment:	M1
Electromagnetic environment:	E2
Location:	Integral or Remote (<200m cable)
Reverse Flow:	Bi-directional measurement
Minimum straight length of inlet pipe:	0D (0)
Minimum straight length of outlet pipe:	0D (0) Can be installed in any position
Orientation:	Mains 85 to 265V AC
Power Supply:	Frequency 50Hz or 60Hz

3.2.1 Software Versions

3.2.1 Software Versions

	Software i.d.	Software Version	Checksum
Main Application	VKK WAJC2103	01.00.01	0xACF6D1B8
Bootloader	VKK WAJC2101	01.00.00	0x1E0C83AD
Update Application Manager	VKK WAJC2102	01.00.00	0x6BA1C132
Pre Amp Sensor Memory	WAJC2004	1.00	0x30804391
Pre-Amp EEROM	WAJC2033	1.03	1CF560E7

4 PERIPHERAL DEVICES AND INTERFACES

4.1 Interfaces

The instrument may have the following interfaces:

- (i) Digital Pulse output
- (ii) Scancoder Remote Reading Interface
- (iii) RS232 Communications
- (iv) Optional GSM Radio Communications
- (v) Optional Pressure Transducer Connection
- (vi) RS485 ModBus

4.2 Peripheral devices

The instrument may be connected to any peripheral device that has been issued with a test certificate or parts certificate by a Notified Body responsible for Annex B (MI-001) under Directive 2004/22/EC in any Member State and bears the CE marking of conformity to the relevant directives; or

A peripheral device without a test certificate may be connected under the following conditions:

- it bears the CE marking for conformity to the EMC Directive;
- it is not capable of transmitting any data or instruction into the flow meter, other than to check for correct data transmission or validation / verification;
- Any Pulse / Frequency Output receiving equipment
- Alarm Contact Output receiving equipment
- RS232 communications equipment
- Scancoder reader via wired connection or an inductive pad
- RS485 ModBus equipment

5 APPROVAL CONDITIONS

The certificate is issued subject to the following conditions:

5.1 Legends and inscriptions

5.1.1 The instrument bears the following legends:

'CE' marking
Supplementary metrology marking
Notified body identification number
Accuracy class
Serial number
Manufacturers mark or name
Certificate number
Permanent flow rate Q_3
Flowrate range Q_3/Q_1 (R)

6 LOCATION OF SEALS AND VERIFICATION MARKS

6.1 Securing the software

After installation and commissioning, to prevent unauthorised modification of any metrological parameter the transmitter must be put into “metrological read-only” mode, thereby making all metrological parameters read only. For this product, it is achieved by a wire link between two pins on the connector shown in Figure 3. ABB supplies either the plug WEBX0060 or adapter lead WEBC2025 which have this link made, also shown in Figure 3. The adapter is to facilitate connection of pressure transducers which do not have this “metrological read only” shorting link already made.

The “metrological read only” mode works on all interfaces including the GSM / SMS and Modbus communication option.

6.2 Sealing the transmitter

Anti tamper seals should be fitted, as shown in Figure 4.

7 ALTERNATIVES

There are no alternatives at present.

8 ILLUSTRATIONS

- Figure 1 AquaMaster 3 Mains Powered Integral Form
- Figure 2 AquaMaster 3 Mains Powered Remote Form
- Figure 3 Transmitter “Metrological Read Only” Link
- Figure 4 Transmitter Sealing

9 CERTIFICATE HISTORY

ISSUE NO.	DATE	DESCRIPTION
UK/0126/0102	25 March 2011	Type examination certificate first issued.
UK/0126/0102 Revision 1	02 August 2011	Revision 1 Issued Corrections to Front Page: Transmitter model Changed from FER2 to FET2. AquaMaster 3 Model designation FER2 added.



Figure 1 AquaMaster Integral Form

**Note: Mains supply cable not shown on this photograph,
see Figure 2 for the location of mains cable.**



Figure 2 AquaMaster Remote Form

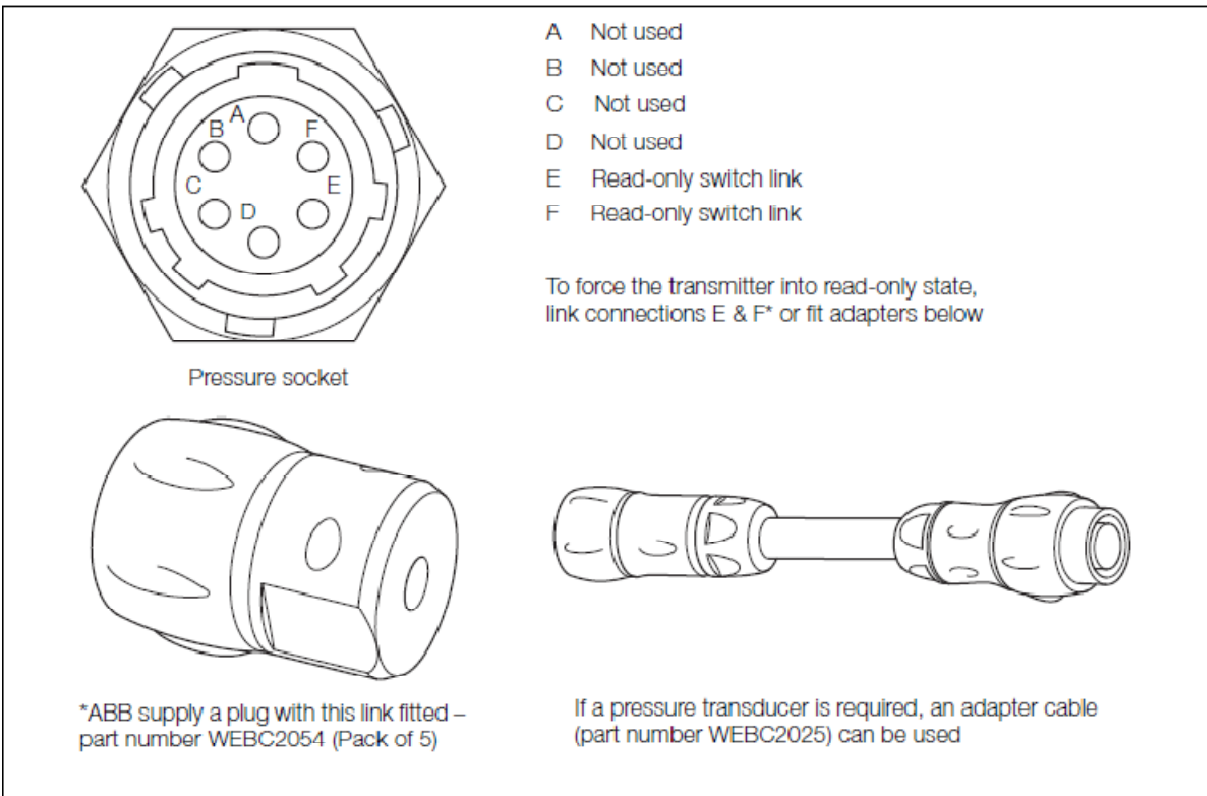

Figure 3 Transmitter “Metrological Read Only” Link

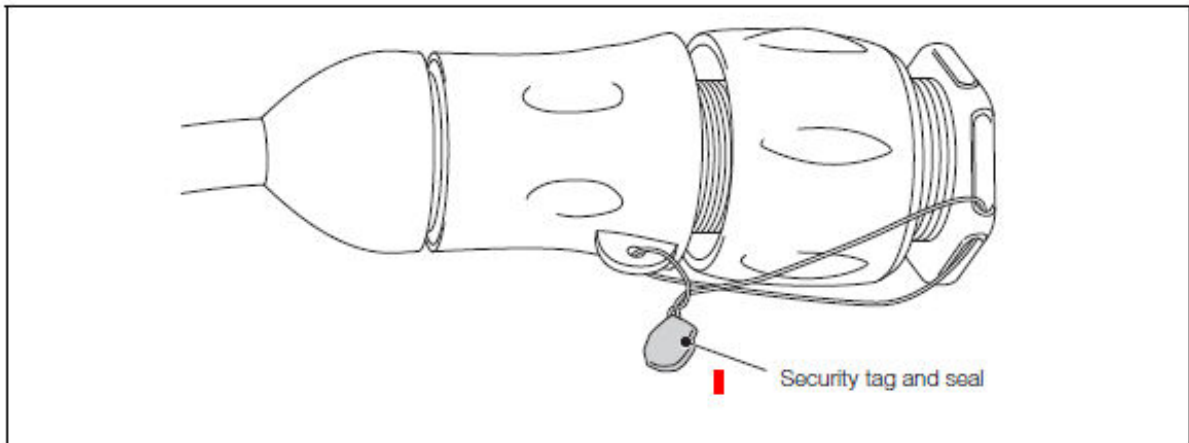

Figure 3 Transmitter Sealing