

EC type-examination certificate UK/0126/0075 Revision 2

issued by

**The National Measurement Office
Notified Body Number 0126**

In accordance with the requirements of the Measuring Instruments (Liquid Fuel delivered from Road Tankers) Regulations 2006 (SI 2006/1259) and the Measuring Instruments (Non-Prescribed Instruments) Regulations 2006 (SI 2006/1270) which implement, in the United Kingdom, Council Directive 2004/22/EC, this certificate of EC type-examination has been issued to:

**Maine Metering Solutions
Maine Group Ltd
Unit 11
15 Trench Road
Mallusk
Co Antrim
BT36 4TY
Northern Ireland**

in respect of: vehicle-mounted meter measuring systems for liquids other than water, designated the CMS DD400 & CMS BD1100.

The necessary data (principal characteristics, alterations, securing, functioning etc) for identification purposes and conditions (when applicable) are set out in the descriptive annex to this certificate.

This revision replaces previous versions of the certificate.

**Issue Date: 25 October 2011
Valid Until: 16 March 2020
Reference No: T1121/0027**

**Signatory: P R Dixon
for Chief Executive**



BIS

**Department for Business
Innovation & Skills**

Descriptive Annex

1 INTRODUCTION

This pattern is a meter measuring system for fitting to a road tanker for the transport and delivery of liquids other than water of low viscosity stored at atmospheric pressure. It comprises a pump, a gas extractor, a meter with a full hose reel and/or an empty hose according to type (paragraph 2). The register may be either electronic or mechanical with a printer.

The system allows:

- i. Metered delivery by pumping (full or empty hose)
- ii. Direct delivery, with or without pumping, without passing through the meter.

2 FUNCTIONAL DESCRIPTION

The designation CMS DD400 applies to assemblies with one or more full hoses only. The designation CMS BD1100 applies to assemblies with one empty hose and one full hose. The hydraulic systems for both types are shown in Figures 1 and 2 respectively. Both types may be either 50mm or 75mm systems. Typical layout for truck applications is shown in Figure 3.

2.1 List of gas extractors

Manufacturer	Model designation	EEC pattern approval / Evaluation certificate
Total Control Systems	TCS 740-xx series	GB-1273 (Eval-cert)
Total Control Systems	TCS 745-xx series	GB-1273 (Eval-cert)
Liquid Controls	A8100	EEC Cert No UK 81 1783
Blackmer/Mouvex	DMX Gas Separator	EEC Cert No F99.00.522002.0

2.2 List of meters

Manufacturer	Model designation	EEC pattern approval / Evaluation certificate
Total Control Systems	TCS 700-xx series	GB-1273 (Eval-cert)
Liquid Controls	M7	EEC Cert No UK 81 1782
Liquid Controls	M15	EEC Cert No UK 81 1782

2.3 List of registers and ancillary devices

Manufacturer	Device	Type	Model designation	EEC pattern approval / Evaluation certificate
Veeder Root	Register	Mechanical	7887	D 79.5.243.01 D 81.5.243.19
Veeder Root	Preset (optional)	Mechanical	7889	D 83.5.531.12
Veeder Root	Printer	Mechanical	7888	D83.5.521.09
Veeder Root	Register	Electronic	EMR ³	GB-1285 (Eval-cert)
Any	Simple slip printer	Electronic	Any	(as described in an EEC pattern approval or EC Parts certificate)

3 TECHNICAL DATA

3.1 System

Technical data	Field of operation
Accuracy class	0.5
Minimum rate of flow	See table in section 3.2
Maximum working pressure:	10.5 bar
Minimum delivery (MMQ):	See table in section 3.2
Climatic environment:	-10°C to +40°C Open, condensing
Electromagnetic environment:	E3 (vehicle mounted)
Mechanical environment:	M2 (vehicle mounted)
Type of liquid	Liquids other than water of low viscosity (<20mPa.s) except liquefied gases. (refer to manufacturers specifications for suitable products)

The maximum rate of flow, however, must not be greater than the maximum rate of flow of any component of the system.

3.2 Meters

Model designation	Size (mm)	Flow rate range		MMQ* (L)
		Q _{min} (L/min)	Q _{max} (L/min)	
TCS 700-20	50	50	380	50
TCS 700-25	50	50	550	50
TCS 700-30	75	100	760	100
TCS 700-35	75	100	1155	100
M7	50	45	450	50**
M15	76	90	900	50**

Note: * The value of MMQ is subject to the system components used. The lower limit for MMQ may be limited by national legislation.
** MMQ = 100 L when fitted with a printing mechanism

4 APPROVAL CONDITIONS

The certificate is issued subject to the following conditions:

4.1 Legends and inscriptions

The following legends are durably and legibly marked on a plate attached to the system (see Figure 5):

Manufacturer's name:	Compact Metering Systems
Manufacturers designation:	CMS DD400 & CMS BD1100
Serial number:	
Date of manufacture:	
Accuracy class:	0.5
Liquids measured:	
Flow rate range:	L/min
Minimum delivery:	L
Maximum operating pressure:	10.5 bar
Environment	-10°C/+40°C, M3 Vehicle mount
Metrology markings:	CE-mark Supplementary metrology marking Notified Body number
Type Examination certificate	UK/0126/0075

5 LOCATION OF SEALS AND VERIFICATION MARKS

5.1 The CE marking shall be impossible to remove without damaging it. The labels shall be impossible to remove without them being destroyed.

The markings and inscriptions shall fulfil the requirements of Annex I Paragraph 9 of Directive 2004/22/EC.

5.2 Components that may not be dismantled or adjusted by the user will be secured by either a wire and seal or tamper evident label and securing mark. The securing mark may be either:

- a mark of the manufacturer and/or manufacturer's representative, or
- an official mark of a verification officer.

An example of the mark of the manufacturer, and/or manufacturer's representative, is shown in Figure 13. On the front the mark is a Star with MMS in the middle, on the reverse is 0126-69

(Note: 0126 is the Notified Body number, and 69 is the manufacturers ID ref.).

5.2.1 The following items shall be secured:

- (i) the components of the system in accordance with the requirements of the relevant Pattern approval / Evaluation certificates.
- (ii) the components of the system as described below and shown in Figures 5 and 6.

5.2.1.1 Meter Assembly

The following sealing arrangement is common to both the CMS DD400 (Figure 5) and the CMS BD1100 (Figure 6) systems:

- P1 – Sealing of the screws fixing air eliminator to filter housing.
- P2 – Sealing air eliminator (front/rear) cover screws to gas removal pipe fitting.
- P3 – Sealing of the screws fixing filter to meter housing.
- P4 – Sealing of the screws fixing front cover to meter housing.
- P5 – Sealing of the screws fixing rear cover to meter housing.
- P6 – Sealing of the screws at preset's side cover (cut-off adjuster).
- P7 – Sealing of the front cover screws at adjuster/transmission assembly housing (head support).
- P8 – Sealing of the screws fixing register head enclosure to its support.
- P9 – Sealing of the screws fixing preset valve to meter housing.
- P10 – Sealing of the screws fixing register enclosure (and printer when installed) to preset enclosure.
- P11 – Sealing of the preset valve top cover screws.
- P12 – Sealing of the screws fixing air-check valve to preset valve.
- P13 – Sealing of the air-check valve screws to gas removal pipe fitting toward air eliminator.
- P14 – Sealing of the air eliminator (front/rear) cover screws on side not attached to gas removal pipe (typically used for vapour recovery or venting purposes).

5.2.2 Transfer points

The remaining seals downstream of the meter assembly shall be specific for each system outflow alternative, which will obviously depend on the desired transfer point(s).

As detailed above, any connection installed between the outflow of the meter assembly and the final transfer point(s) at any measuring system shall be protected from tampering or fraudulent use. In order to achieve this, the general premise shall be to seal every joint, flange, valve, pipework, etc. downstream of the meter assembly up to the end delivery point(s) installed.

For that purpose, the additional seals for every type of measuring system shall match precisely the following description:

5.2.2.1 CMS DD400 measuring system with one full hose

- P15 – Sealing of the air-check valve screws to pipework inlet flange.
- P16 – Sealing of the pipework outlet flange to full hose assembly inlet flange (hose reel, etc.).
- P17 & P18 – Sealing of the additional flanges along full hose layout as required (long pipework, curves, elastic joints, etc.)

5.2.2.2 CMS DD400 measuring systems with two full hoses

- P15 – Sealing of the air-check valve screws to pipework inlet flange.
- P16 – Sealing of the pipework outlet flange to 3-way valve inlet flange.
- P17 – Sealing of the 3-way valve first outlet flange to full hose assembly #1 inlet flange.
- P18 – Sealing of the 3-way valve second outlet flange to full hose assembly #2 inlet flange.
- P19 & P20 – Sealing of the additional flanges along full hoses layouts as required (long pipework, curves, elastic joints, etc.)

5.2.2.3 CMS BD1100 measuring systems with one empty hose and one full hose.

- P15 – Sealing of the air-check valve screws to pipework inlet flange.

6 RECOMMENDED TESTS

The meter measuring system shall be tested at a minimum of two substantially different rates of flow between the maximum and minimum rates of flow.

The meter measuring system shall be tested by a minimum of three repeat runs at each rate of flow. Each run shall have a minimum duration of one minute.

Due regard shall be paid to the viscosity of the liquid used for the verification tests to ensure that the permitted limits of error are not likely to be exceeded when other liquids which the system is intended to measure are metered.

7 AUTHORISED ALTERNATIVES

7.1 Having any other compatible gas extractor that has been issued with a Parts Certificate by a Notified Body responsible for Annex B (MI-005) under Directive 2004/22/EC in any Member State, and bears the CE marking of conformity to the relevant directive.

7.2 Having the EMR³ Register Electronic, as described in GB-1285, with a temperature correction algorithm.

7.2.1 The temperature correction algorithm is stored in the EMR³ for automatic volume correction when in temperature correction mode. Temperature correction may be implemented using an optional temperature probe. A thermometer icon is displayed when being used in temperature correction mode.

7.2.2 Electronic Temperature Probe

This is a two wire thermistor which is used as an associated measuring instrument. It is manufactured by US Sensor Corporation and has part number USP2119. The temperature sensor (Figure 7) is installed in the fuel delivery pipe within one metre of the flow meter; a typical installation is shown in Figure 7.

Other temperature probes may be used in place of the above thermistor provided they meet the accuracy requirements of OIML R117 paragraph 2.7.2.

Note: PT100 type temperature probes will not operate with the EMR³ system.

7.2.3 Calibration of Temperature Probe

The temperature probe is calibrated at 0 Degrees Centigrade in the C&C mode with the probe immersed in a water/ice mixture. Select 0 Degrees C for the Calibration Temp on the EMR³ whilst in C&C Mode. (Refer to EMR³ Set Up and Operation Manual No. 577013-766. Revision L for detailed information on using the setup menus). After calibration, this setting cannot be altered without breaking the seal on the register head.

7.3 Having a Product Return as described below.

7.3.1 For product transfer, an electronic signal is sent to the EMR³ once the product return guard bar is lifted to signify to the system that product transfer is in use. The quantity of product to be returned is entered on the pre-set device and pumping is started.

7.3.2 When the product return is complete, the meter pre-set shuts off product flow and the delivery nozzle is manually closed. The blow down valve is manually opened. This allows compressed air from the air tank to purge product from the bottom loading pipework back into the tank. Duration is normally 2-5 seconds. The delivery nozzle is then removed from the product return spout and the product return guard bar is lowered into its rest position, which then deactivates the product return system. The system will print the words 'product transfer' on the delivery ticket.

7.4 Having an alternative sealing arrangement for Temp Probe (Figure 9).

7.5 Having an alternative system identification plate, bearing the manufacturer's name of Compact Metering Solutions (Figure 10).

7.6 Having an alternative system identification plate, bearing the manufacturer's name of Maine Metering Systems (Figure 11).

7.7 Having alternative Manufacturers designations of TruFlow400 & TruFlow1000 for the CMS DD400 & CMS BD1100 respectively.

7.8 Having a control box (option) with the pneumatic control cabinet and EMR³ display combined in one stainless steel cabinet (Figure 12).

7.9 Having the Pneumatic 2 Stage Preset Valve replaced by a Pneumatic Ball or Butterfly Valve (Figure 14). The valve is secured as described in section 5.2.1.1.

8 ILLUSTRATIONS

- Figure 1 Hydraulic diagram CMS DD400
- Figure 2 Hydraulic diagram CMS BD1100
- Figure 3 Typical layout for truck application
- Figure 4 Example of system identification plate
- Figure 5 CMS DD400 seals
- Figure 6 CMS BD1100 seals
- Figure 7 Temp Probe and Sealing arrangement
- Figure 8 Display showing Volume Correction legend
- Figure 9 Example of alternative Sealing arrangement for Temp Probe
- Figure 10 Example of alternative system identification plate
- Figure 11 Example of alternative system identification plate
- Figure 12 Combined control box
- Figure 13 Example of the mark of the manufacturer (Front & Rear face)
- Figure 14 Pneumatic Butterfly Valve

CERTIFICATE HISTORY

ISSUE NO.	DATE	DESCRIPTION
UK/0126/0075	17 March 2010	Type examination certificate first issued
UK/0126/0075 Rev 1	16 November 2010	<p><u>Revision 1 issued</u></p> <p>Section 2.1, Addition of components Section 2.2, Addition of components Section 2.3, change of wording for printers Section 3.2, details of M7 & M15 included and change to wording regarding MMQ Section 7 renumbered as section 8 Section 8 renumbered as section 9 Addition of new section 7 AUTHORISED ALTERNATIVES Addition of Figures 7, 8, 9 and 10</p>
UK/0126/0075 Rev 2	25 October 2011	<p>Change to manufacture's name (front page, and section 4.1).</p> <p>Change to wording in section 4.1, "Notified Body verification mark" changed to "Notified Body number".</p> <p>Addition of wording, in section 5.2:</p> <p><i>An example of the mark of the manufacturer, and/or manufacturer's representative, is shown in Figure 13. On the front the mark is a Star with MMS in the middle, on the reverse is 0126-69</i></p> <p><i>(Note: 0126 is the Notified Body number, and 69 is the manufacturers ID ref.).</i></p> <p><i>The following wording is added to section 5.2.1 (i) "Evaluation certificates".</i></p> <p>Addition of sections 7.6, 7.7, 7.8 and 7.9 Addition of Figures 11, 12 13 & 14</p>

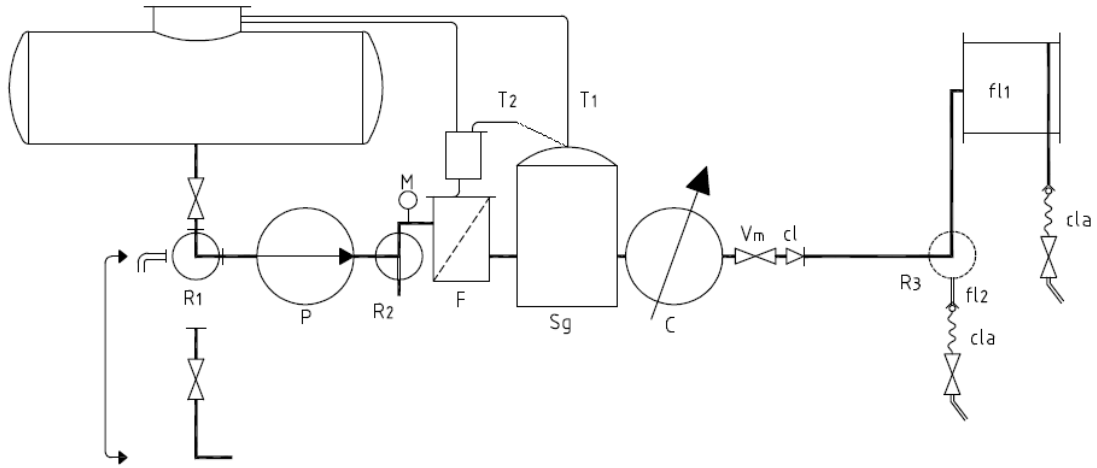

R1	TWO WAY VALVE (OPTIONAL)
P	PUMP
M	MANOMETER
R2	TWO WAY VALVE (OPTIONAL)
F	FILTER
Sg	AIR ELIMINATOR/GAS EXTRACTOR
T1,T2	GAS EVACUATION DEVICE
C	METER
Vm	HANDLING VALVE (PRESET) OPTIONAL
cl	AIR CHECK/BACK PRESSURE CHECK/NDN-RETURN VALVE
V1	SIGHT GLASS/EMPTY HOSE
fl1	FULL HOSE #1
fl2	FULL HOSE #2 (OPTIONAL)
cla	NDN-RETURN VALVE (KEEP HOSE FULL OF LIQUID)
Re	HOSE SELCTION DEVICE (OPTIONAL)

Rev	Detail	Filename	Drawn by	Date
		MT.01.00	S. Paul	02/02/10
<p>THE COPYRIGHT IN THIS DRAWING IS THE PROPERTY OF COMPACT METERING SOLUTIONS AND MAY NOT BE REPRODUCED IN WHOLE OR PART, IN ANY FORM, WITHOUT THE PERMISSION OF THE OWNER</p> <p>COMPACT METERING SOLUTIONS</p> <p>47 Redford Road Ballymena, Co. Antrim, BT43 5PR Tel: 02825 882882 Fax: 02825 882880</p>		<p>1st Angle Projection</p>	Project Title	
			<p>Drawing Title</p> <p style="text-align: center;">Hydraulic Schematic Full Hose & Optional Full Hose</p>	
		Scale		Drawing Number
NTS		DD400		0
Sheet		Edition		Sheet
A4		0		1/1

Figure 1 Hydraulic diagram CMS DD400

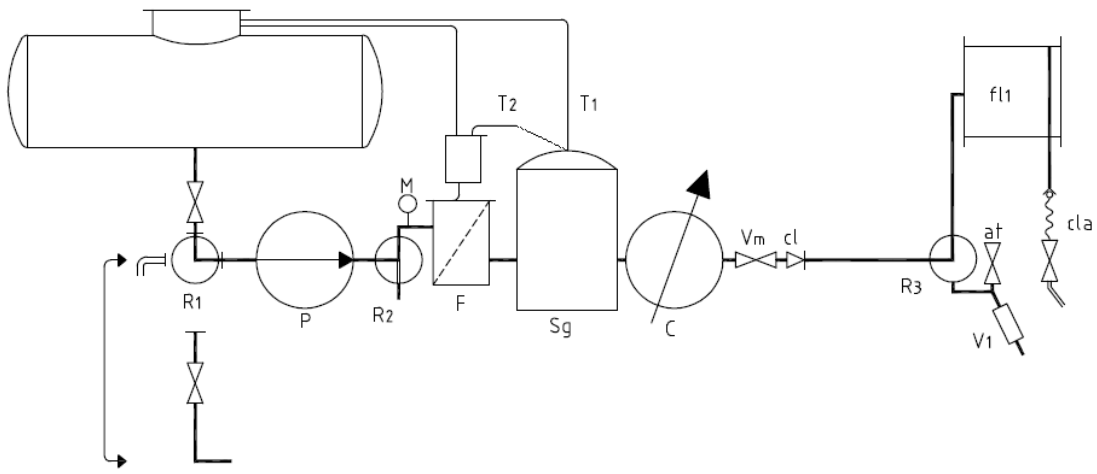

R1	TWO WAY VALVE (OPTIONAL)
P	PUMP
M	MANOMETER
R2	TWO WAY VALVE (OPTIONAL)
F	FILTER
Sg	AIR ELIMINATOR/GAS EXTRACTOR
T1,T2	GAS EVACUATION DEVICE
C	METER
at	VENTING VALVE (EMPTY HOSE)
Vm	HANDLING VALVE (PRESET) OPTIONAL
cl	AIR CHECK/BACK PRESSURE CHECK/NON-RETURN VALVE
V1	SIGHT GLASS/EMPTY HOSE
fl1	FULL HOSE
cla	NON-RETURN VALVE (KEEP HOSE FULL OF LIQUID)
R3	HOSE SELCTION DEVICE

Rev	Detail	Filename	Drawn by	Date
		MT.01.00	S. Paul	02/02/10
<p>THE COPYRIGHT IN THIS DRAWING IS THE PROPERTY OF COMPACT METERING SOLUTIONS AND MAY NOT BE REPRODUCED IN WHOLE OR PART, IN ANY FORM, WITHOUT THE PERMISSION OF THE OWNER</p> <p>COMPACT METERING SOLUTIONS</p> <p>47 Redford Road Ballymena, Co. Antrim, BT43 5PR Tel: 02825 882882 Fax: 02825 882880</p>		 1st Angle Projection		
		<p>Project Title</p> <p>Drawing Title</p> <p style="text-align: center;">Hydraulic Schematic Full Hose & Empty Hose</p>		
		Scale	Drawing Number	Edition
		NTS	BD1100	0
		Sheet		Sheet
		A4		1/1

Figure 2 Hydraulic diagram CMS BD1100

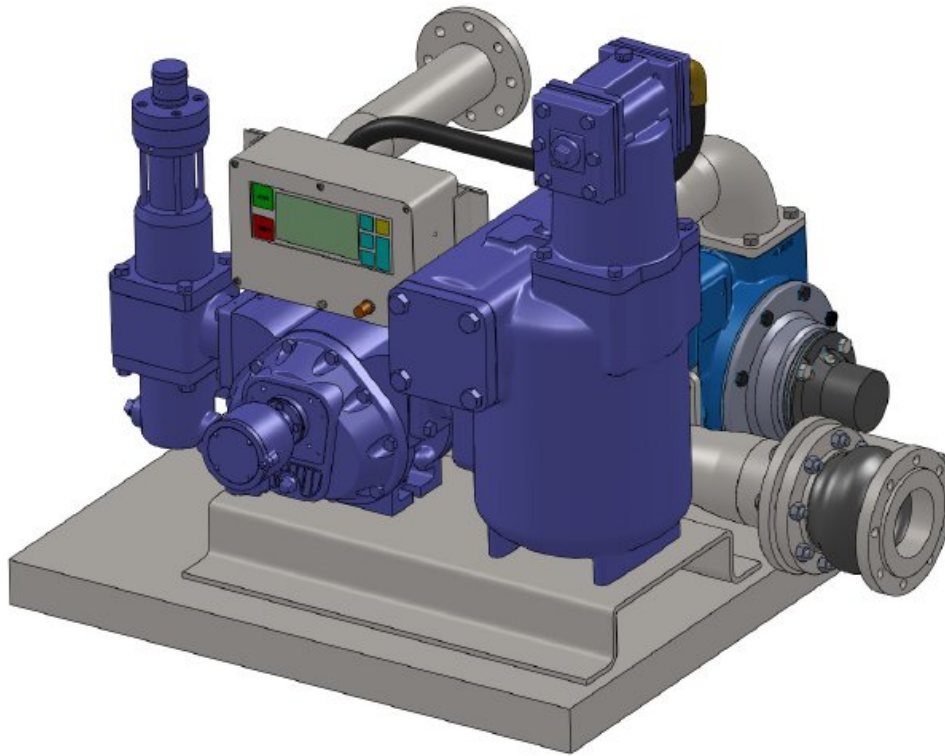



Figure 3 Typical layout for truck application



CMS
Compact Metering Solutions

Measuring System

Compact Metering Solutions
47 Redford Road
Cullybackey
N. Ireland
BT43 5PR
TEL: 02825 882 882
www.compactmetering.com

Model:	CMS DD 400
Serial number:	
Manufacturing date:	
Liquids measured:	PETROLEUM PRODUCTS
Accuracy class	0.5 LIQUIDS < 20mPa.s
Measuring range:	0-99,999.9 LITRES
Flow rate range:	50-550 L/MIN
Minimum delivery	50 LITRES
Maximum pressure:	10.5 BAR
Environment:	-10°C / +40°C , M3
Electrical supply:	12/24 V DC, 10A
Metrology approvals:	 M 10 xxxx <small>Type Examination Certificate UK/0126/XXXX</small>

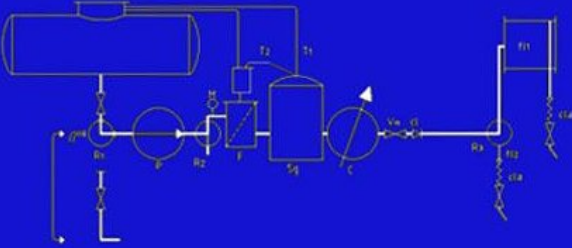

Figure 4 Example of system identification plate

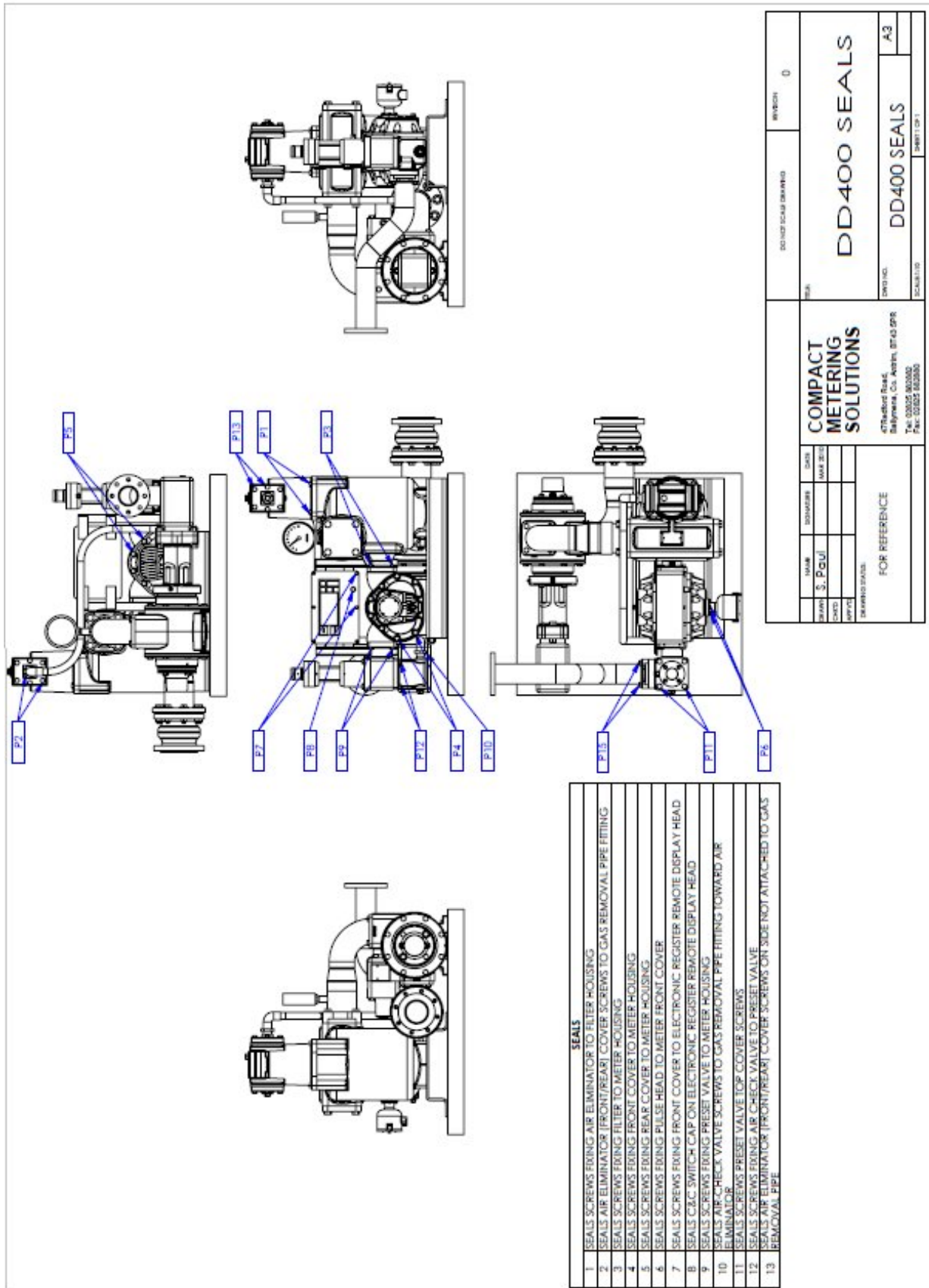

Figure 5 CMS DD400 sealing

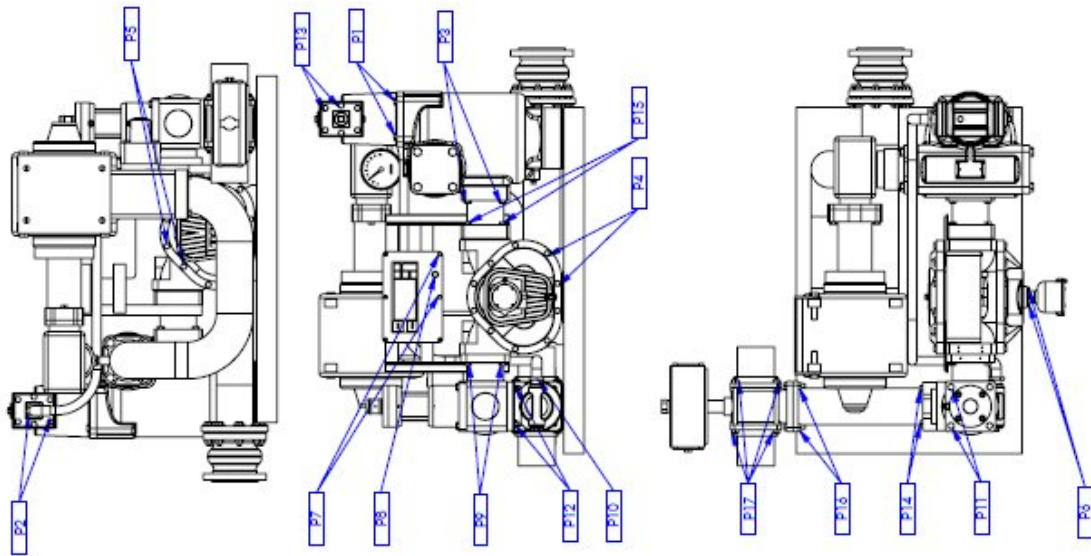
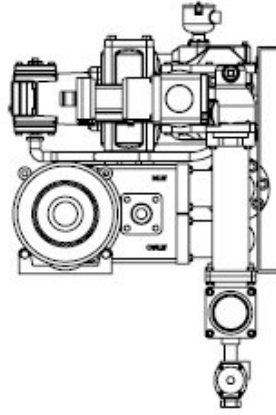

Figure 6 CMS BD1100 sealing



SEALS	
1	SEALS SCREWS FIXING AIR ELIMINATOR TO FILTER HOUSING
2	SEALS AIR ELIMINATOR (FRONT/REAR) COVER SCREWS TO GAS REMOVAL PIPE FITTING
3	SEALS SCREWS FIXING FILTER TO METERS ADAPTOR PIPE
4	SEALS SCREWS FIXING FRONT COVER TO METER HOUSING
5	SEALS SCREWS FIXING REAR COVER TO METER HOUSING
6	SEALS SCREWS FIXING PULSE HEAD TO METER FRONT COVER
7	SEALS SCREWS FIXING FRONT COVER TO ELECTRONIC REGISTER REMOTE DISPLAY HEAD
8	SEALS CALC SWITCH CAP ON ELECTRONIC REGISTER REMOTE DISPLAY HEAD
9	SEALS SCREWS FIXING PRESSURE VALVE TO METER HOUSING
10	SEALS AIR-CHECK VALVE SCREWS TO GAS REMOVAL PIPE FITTING TOWARD AIR ELIMINATOR
11	SEALS SCREWS FIXING AIR CHECK VALVE TO PRESSURE VALVE
12	SEALS AIR ELIMINATOR (FRONT/REAR) COVER SCREWS (ON SIDE NOT ATTACHED TO GAS REMOVAL PIPE)
13	SEALS SCREWS FIXING DISCHARGE PIPEWORK TO AIR CHECK VALVE
14	SEALS SCREWS FIXING METER ADAPTOR PIPE TO METER
15	SEALS SCREWS FIXING OUTLET PIPEWORK TO 2 WAY VALVE INLET
16	SEALS SCREWS FIXING OUTLET FLANGES TO VALVE BODY
17	SEALS SCREWS FIXING VALVE OUTLET FLANGES TO VALVE BODY

DATE	ISSUES	DATE	REVISION
REVISED	5. P001	04/04/2010	0
COMPACT METERING SOLUTIONS 477 Bedford Road, Melbourne, Vic. Austrn. 3143 SPR Tel: (03) 958 80280 Fax: (03) 958 80280			
DRAWING SCALE: FOR REFERENCE			
BD1100 SEALS		BD1100 SEALS	
DWG NO.		SHEET 1 OF 1	
A3			

Copyright Compact Metering Solutions. This drawing and/or any part thereof must not be reproduced without permission of the owner.

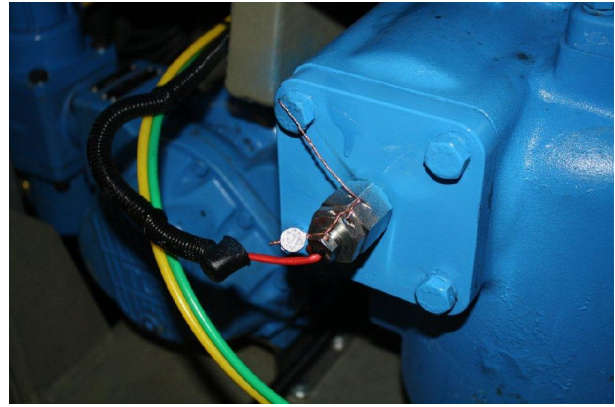

Figure 7 Temp Probe and Sealing arrangement



Figure 8 Display showing Volume Correction legend



Figure 9 Example of alternative Sealing arrangement for Temp Probe

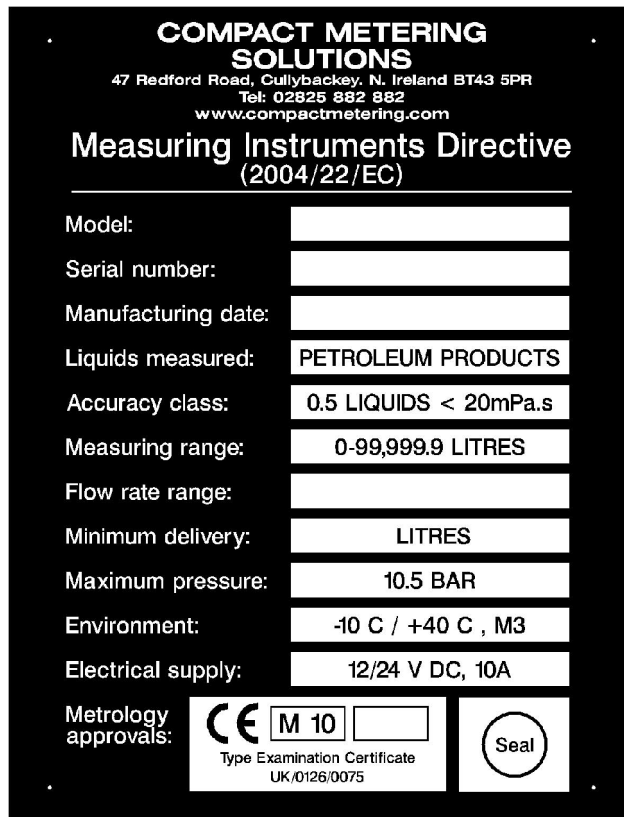

Figure 10 Example of alternative system identification plate

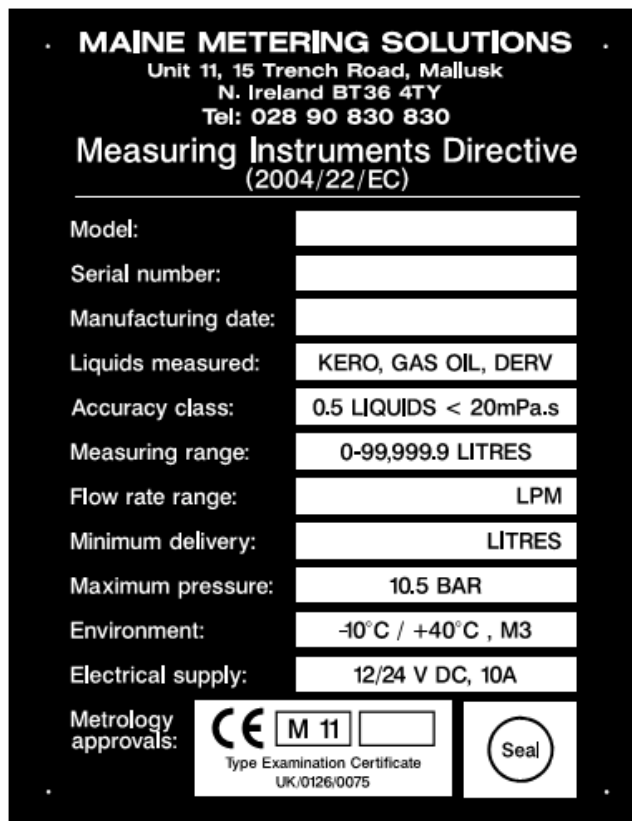

Figure 11 Example of alternative system identification plate



Figure 12 Combined control box

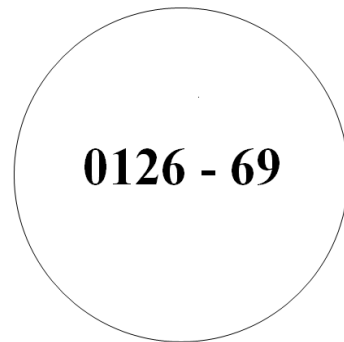
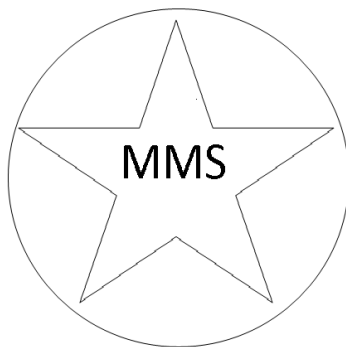

Figure 13 Example of the mark of the manufacturer (Front & Rear face)



Figure 14 Pneumatic Butterfly Valve